

Service • Assistenza • Dienstverlening • Serwis Servis • Szerviz • Сервисная служба	
Name • Nom • Nome • Naam • Nazwa • Jméno • Názov • Név • Denumire • İsim • Название	
Nr. • No. • N° • Номер • Č • Sz	
Typ • Type • Tip • Típus • Tipo • Тип	
	
	

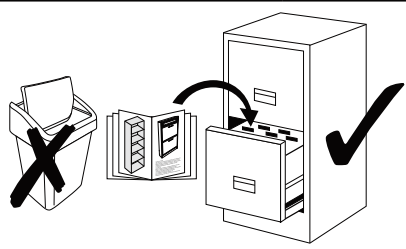

**MAX: 115 KG**

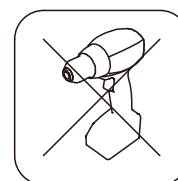

- |   |                                     |
|---|-------------------------------------|
| <b>(D)</b> Montageanleitung             | <b>(GB)</b> Assembly instructions   |
| <b>(FR)</b> Notice de montage           | <b>(IT)</b> Istruzioni di montaggio |
| <b>(NL)</b> Handleiding voor de montage | <b>(PL)</b> Instrukcja montażu      |
| <b>(CZ)</b> Montážní návod              | <b>(SK)</b> Návod na montáž         |
| <b>(HU)</b> Szerelési útmutató          | <b>(RO)</b> Instrucțiuni de montaj  |
| <b>(TR)</b> Montaj talimatı             | <b>(RU)</b> Инструкция по монтажу   |

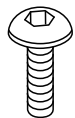
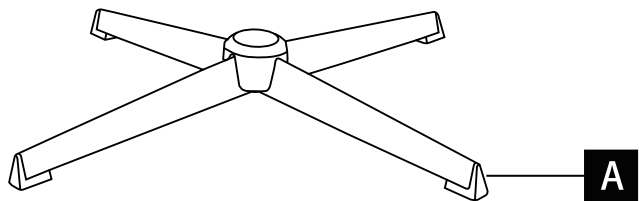
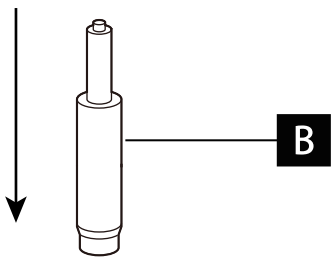
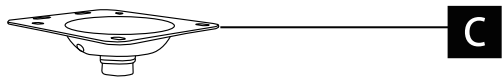
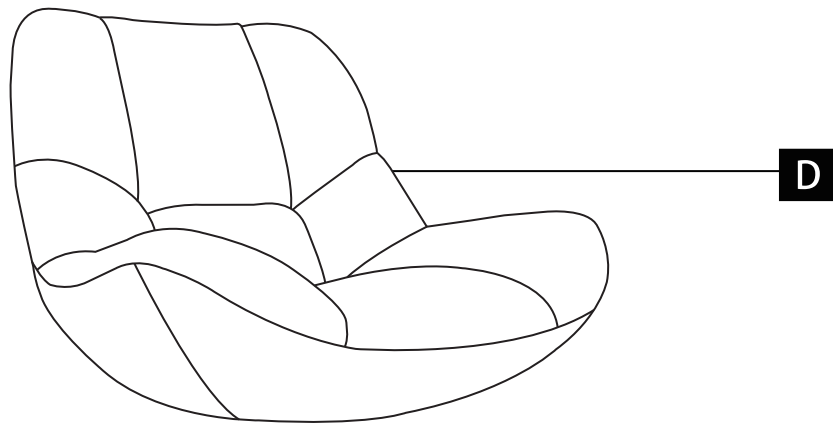

**E** x4



**F** x4



**G** x1

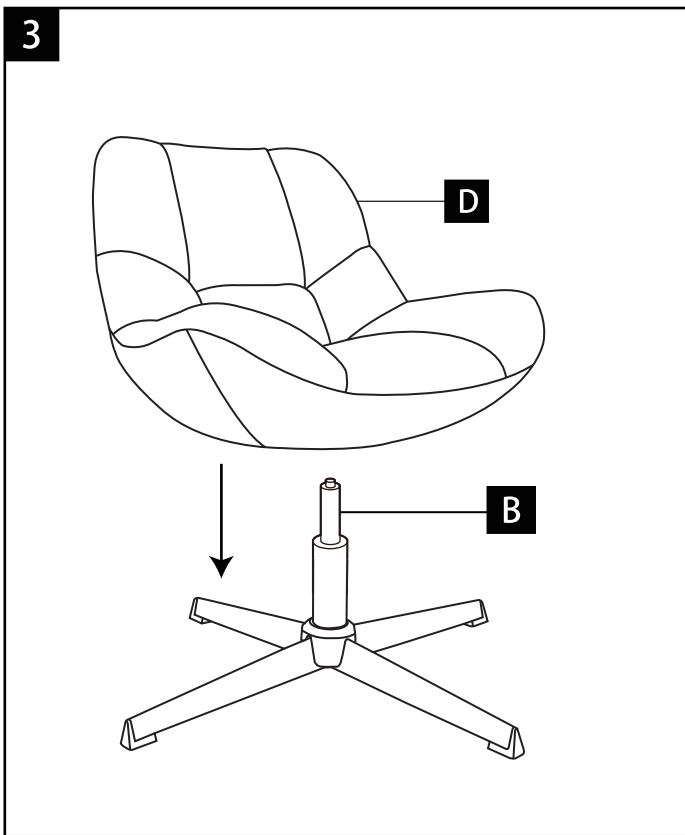
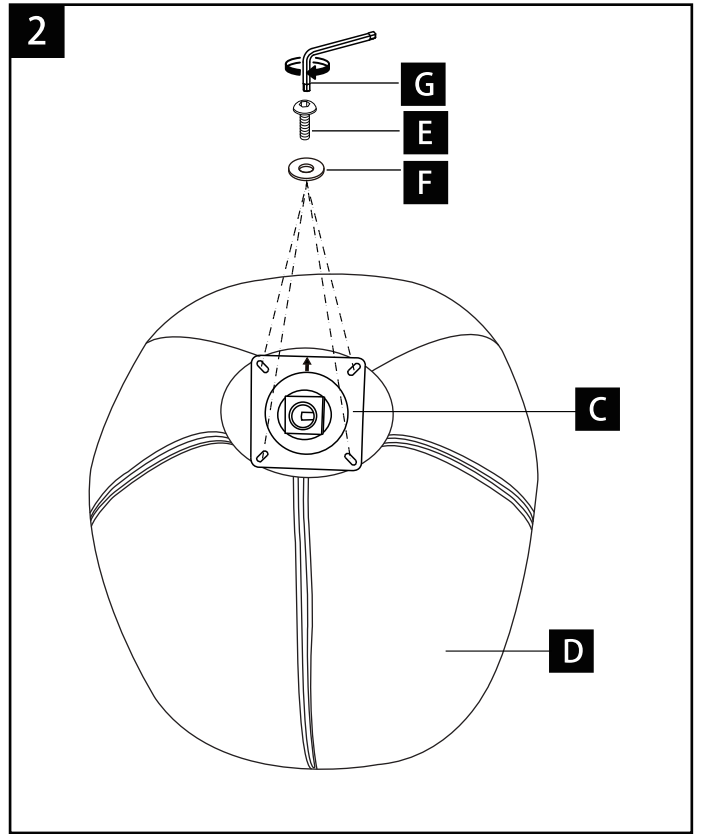
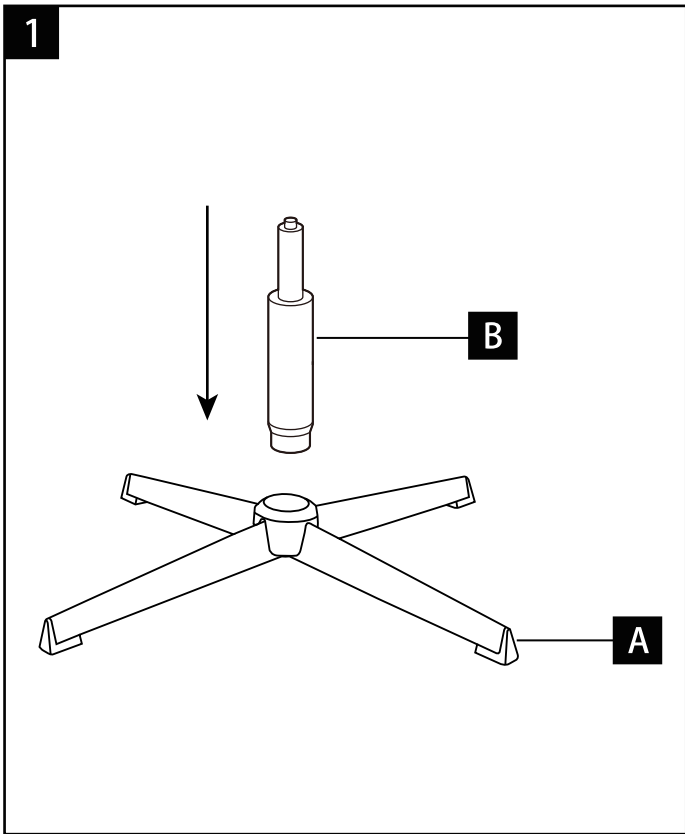

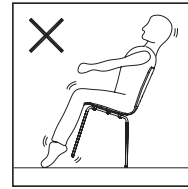

**MAX: 115 KG**



	<b>MAXIMUM LOADS</b>
<b>GB</b>	Do not exceed the maximum loads specified. Otherwise, the furniture may sustain damage or be irreparably damaged.
	<b>CHARGES MAXIMUM</b>
<b>FR</b>	Ne dépassez pas les charges maximales spécifiées. Dans le cas contraire, les meubles pourraient subir des dommages ou être irrémédiablement endommagés.
	<b>MAXIMALE BELASTUNGEN</b>
<b>D</b>	Überschreiten Sie nicht die angegebenen Höchstlasten. Andernfalls kann es zu Schäden oder irreparablen Schäden an den Möbeln kommen.
	<b>CARGAS MÁXIMAS</b>
<b>ES</b>	No exceda las cargas máximas especificadas. De lo contrario, los muebles podrían sufrir daños o sufrir daños irreparables.
	<b>CARICHI MASSIMI</b>
<b>IT</b>	Non superare i carichi massimi specificati. In caso contrario i mobili potrebbero danneggiarsi o danneggiarsi irrimediabilmente.

<b>GB</b>	<b>STABILITY</b> After approx. 5 weeks, tighten all screws and load-bearing connecting parts to ensure permanent stability	<b>GB</b>	<b>CLEANING</b> Please only clean with a duster or a damp cloth. Do not use any abrasive cleaners.
<b>FR</b>	<b>LA STABILITÉ</b> Après env. 5 semaines, serrez toutes les vis et pièces de liaison porteuses pour assurer une stabilité permanente	<b>FR</b>	<b>NETTOYAGE</b> Veuillez nettoyer uniquement avec un plumeau ou un chiffon humide. N'utilisez pas de nettoyeurs abrasifs.
	<b>STABILITÄT</b>		<b>REINIGUNG</b>
<b>D</b>	Nach ca. 5 Wochen alle Schrauben und tragenden Verbindungsteile nachziehen, um eine dauerhafte Stabilität zu gewährleisten	<b>D</b>	Bitte nur mit einem Staubwedel oder einem feuchten Tuch reinigen. Verwenden Sie keine Scheuermittel.
	<b>ESTABILIDAD</b>		<b>LIMPIEZA</b>
<b>ES</b>	Después de aprox. 5 semanas, apretar todos los tornillos y piezas de conexión portantes para garantizar una estabilidad permanente	<b>ES</b>	Limpie únicamente con un plumero o un paño húmedo. No utilice limpiadores abrasivos.
<b>IT</b>	<b>STABILITÀ</b> Dopo ca. 5 settimane serrare tutte le viti e gli elementi di collegamento portanti per garantire una stabilità duratura	<b>IT</b>	<b>PULIZIA</b> Si prega di pulire solo con uno spolverino o un panno umido. Non utilizzare detergenti abrasivi.

<b>WARNING: CHILD SAFETY HAZARD</b>			
<b>GB</b>	Ensure that children do not put any small parts such as nuts, caps or the like in their mouth. They could swallow and choke them!	<b>GB</b>	This product is not a toy! Do not allow children to play with the packaging. They could suffocate or injure themselves with the packaging.
<b>AVERTISSEMENT : RISQUE POUR LA SÉCURITÉ DES ENFANTS</b>			
<b>FR</b>	Assurez-vous que les enfants ne mettent pas de petites pièces telles que des écrous, des bouchons ou autres dans leur bouche. Ils pourraient les avaler et les étouffer !	<b>FR</b>	Ce produit n'est pas un jouet! Ne laissez pas les enfants jouer avec l'emballage. Ils pourraient s'étouffer ou se blesser avec l'emballage.
<b>WARNING: GEFÄHR FÜR DIE SICHERHEIT VON KINDERN</b>			
<b>D</b>	Achten Sie darauf, dass Kinder keine Kleinteile wie Nüsse, Kappen oder Ähnliches in den Mund nehmen. Sie könnten sie verschlucken und ersticken!	<b>D</b>	Dieses Produkt ist kein Spielzeug! Erlauben Sie Kindern nicht, mit der Verpackung zu spielen. Sie könnten an der Verpackung ersticken oder sich verletzen.
<b>ADVERTENCIA: RIESGO PARA LA SEGURIDAD DE LOS NIÑOS</b>			
<b>ES</b>	Asegúrese de que los niños no se lleven a la boca piezas pequeñas como nueces, tapas o similares. ¡Podrían tragárselos y asfixiarse!	<b>ES</b>	¡Este producto no es un juguete! No permita que los niños jueguen con el embalaje. Podrían asfixiarse o lesionarse con el embalaje.
<b>ATTENZIONE: PERICOLO PER LA SICUREZZA DEI BAMBINI</b>			
<b>IT</b>	Assicurarsi che i bambini non mettano in bocca piccole parti come noci, cappucci o simili. Potrebbero inghiottirli e soffocarli!	<b>IT</b>	Questo prodotto non è un giocattolo! Non permettere ai bambini di giocare con l'imballo. Potrebbero soffocare o ferirsi con l'imballaggio.



**Dorel Home Europe Ltd**  
**Alphason House, 244 Swan Lane**  
**Hindley Green, Wigan WN2 4EY UK**  
**cseurope@dorel.com 01942 524100**