

5042296COM Ellington Double Door Cabinet

Ameriwood
HOME

Date of Purchase: ____/____/____
Lot Number:

B345042296COM00UD

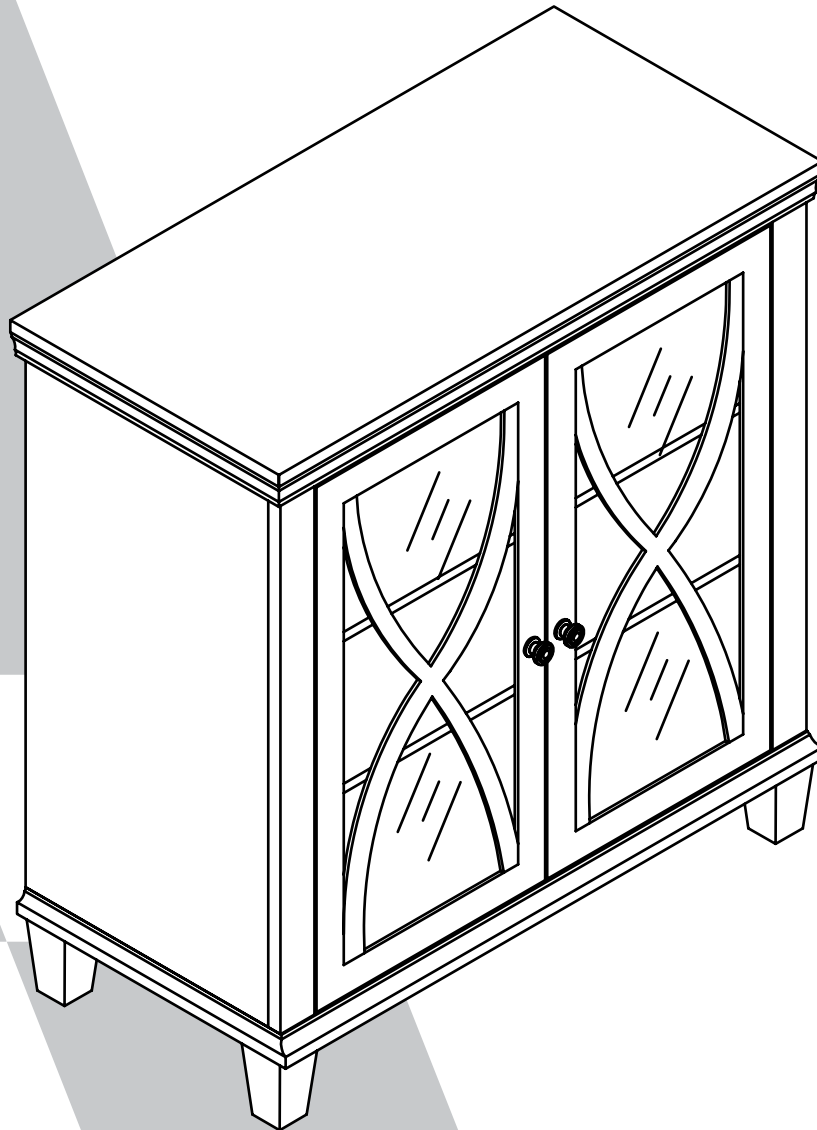

THIS INSTRUCTION BOOKLET CONTAINS **IMPORTANT** SAFETY INFORMATION. PLEASE READ AND KEEP FOR FUTURE REFERENCE.

Do Not Return This Product!

Contact our customer service team for help first
Call: 01942 524100
E-mail: cseurope@dorel.com



WARNING

- Unit can tip over causing severe injury or death.
- Anchor unit to stud in wall (if instructed to)
- Do not allow children climb on unit
- Put heavy items on lower shelves or drawers

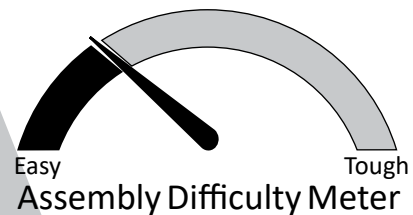

Follow Ameriwood Home



Do NOT return this product!
Contact our friendly customer service team first for help

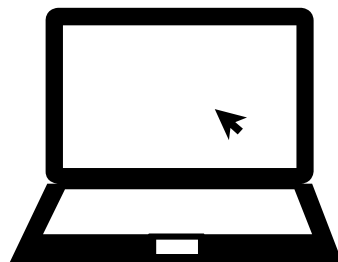
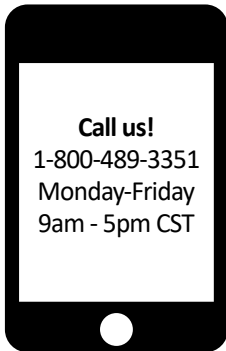

Visit ameriwoodhome.com

Assembly Tips



Helpful Hints

PEOPLE NEEDED FOR ASSEMBLY: **1-2**
ESTIMATED ASSEMBLY TIME: **1 HOUR**

- Open your item in the area you plan to keep it for less heavy lifting
- Identify, sort and count the parts before attempting assembly
- Compression dowels are tapped in with a hammer
- Slides are labeled with a R (right) and L (left) for proper placement
- Make sure to always face the point on the top of the Cam Lock towards the outer edge
- Use all the nails provided for the back panel and spread them out equally
- Back Panel must be used to make sure your unit is sturdy
- Do NOT use harsh chemicals or abrasive cleaners on this item
- Never push, pull, or drag your furniture



Before You Start

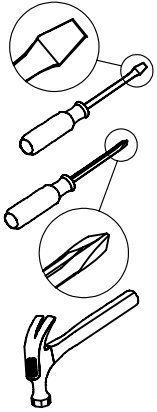
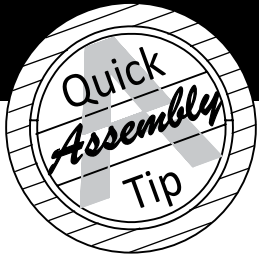

- ✓ Read through each step carefully and follow the proper order
- ✓ Separate and count all your parts and hardware
- ✓ Give yourself enough room for the assembly process
- ✓ Have the following tools: Flat Head Screwdriver, #2 Phillips Head Screwdriver and Hammer
- ✓ Caution: If using a power drill or power screwdriver for screwing, please be aware to slow down and stop when screw is tight. Failure to do so may result in stripping the screw.

Cam Lock Fastening System

This Cam Lock Fastening System will be used throughout the assembly process.

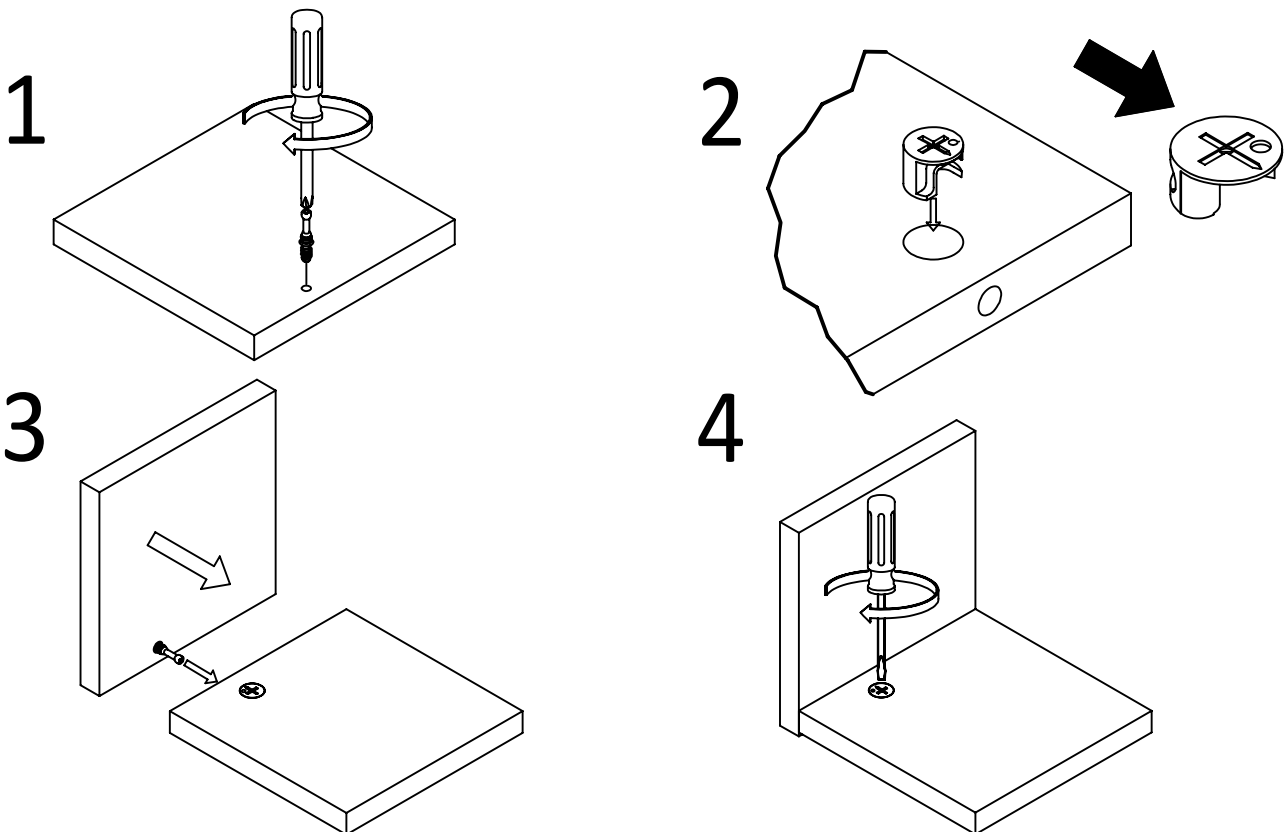

Board Identification

Not actual size

1

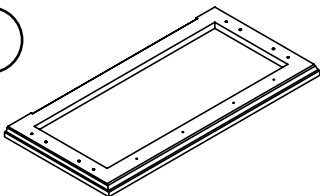

x1
T5042296010UD
TOP PANEL

2

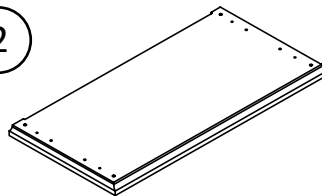

x1
T5042296020UD
BOTTOM PANEL

3

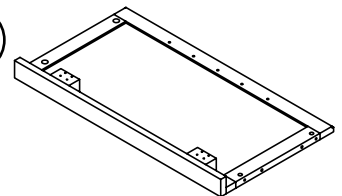

x1
T5042296030UD
LEFT SIDE PANEL

4

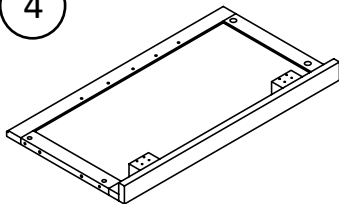

x1
T5042296040UD
RIGHT SIDE PANEL

5

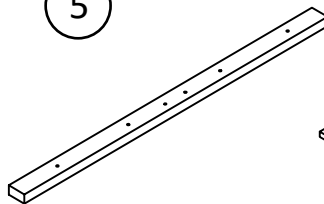

x1
T5042296050UD
TOP BAR

6

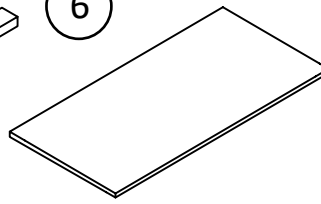

x2
T5042296060UD
ADJUSTABLE SHELF

7

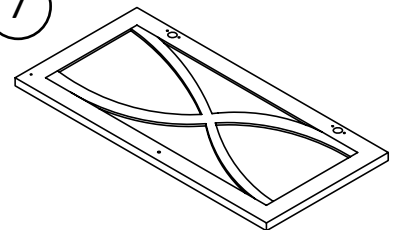

x1
T5042296070UD
LEFT DOOR

8

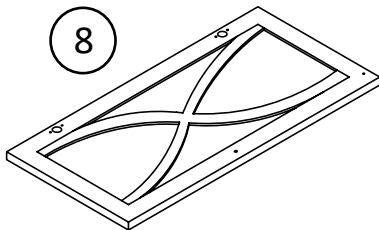

x1
T5042296080UD
RIGHT DOOR

9

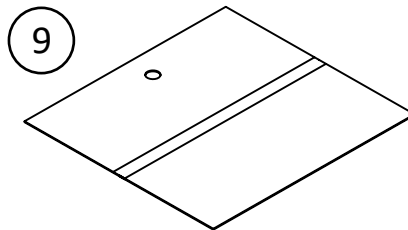

x1
T5042296090UD
BACK PANEL

10

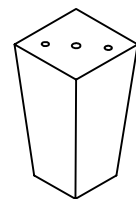

x4
T5042296100UD
FOOT

Part List

Not Actual Size



x4
TUD0001
Cam Bolt
M6 X 23

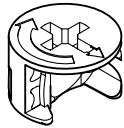

x4
TUD0002
Cam Lock
15-12

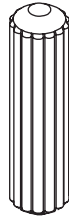

x16
TUD0030
DOWEL
M6 X 30

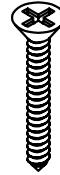

x4
TUD0022
CSK 4 x 30

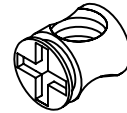

x4
TUD0048
Barrel Nut
1/4" x12

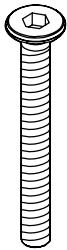

x8
TUD0043
BOLT M6 X 50

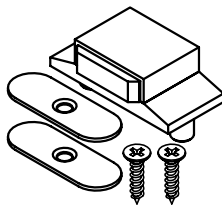

x1
TUD0031
Magnetic Catch

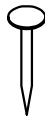

x16
TUD0006
Nail

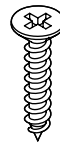

x24
TUD0008
CBS 3.5 x 16

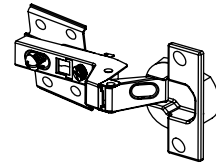

x4
TUD0037
Hinge Ø35

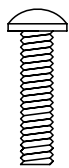

x2
TUD0010
PH M4 X 18



x2
TUD0066
Knob JC-UD006



x8
TUD0018
SHELF HOLDER

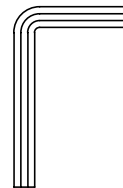

x1
TUD0026
ALLEN KEY M4

Step 1

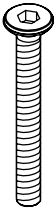

x4
TUD0043



x8
TUD0030

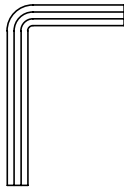

x1
TUD0026

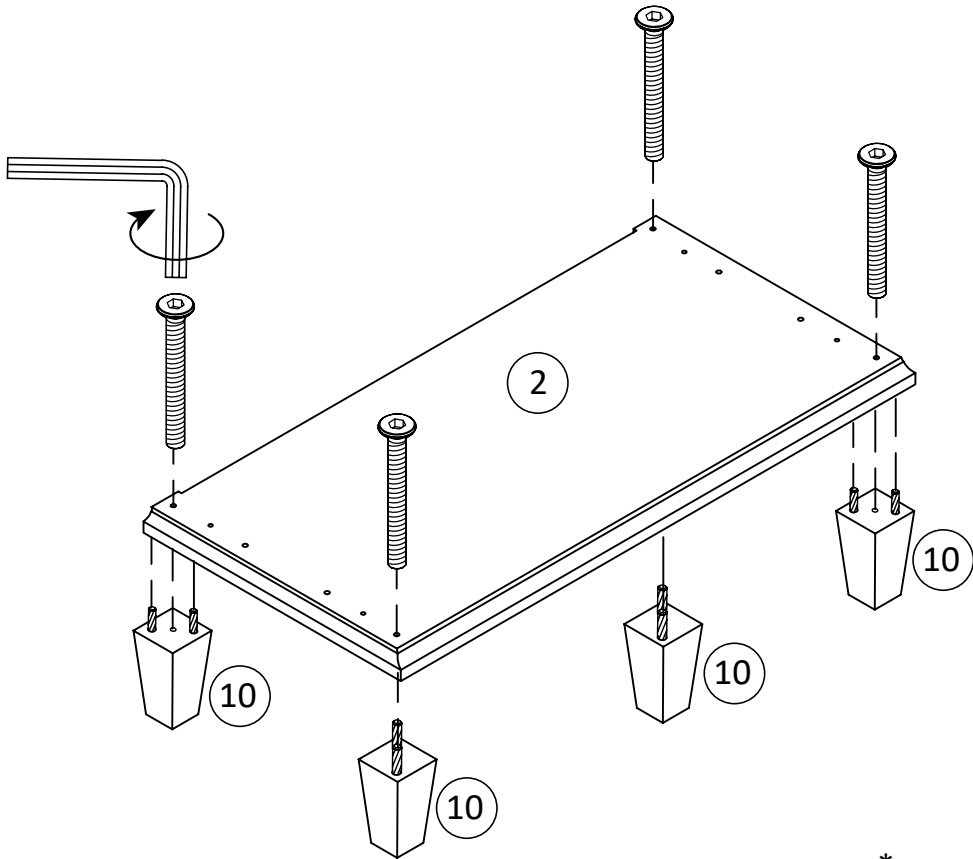
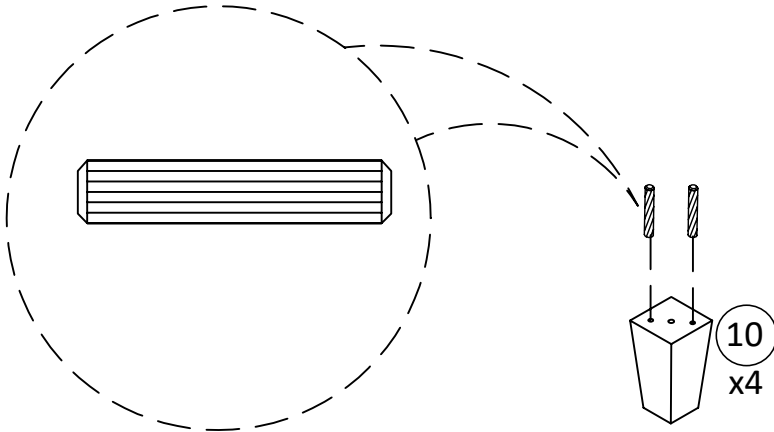

* raw edges are shaded

Step 2

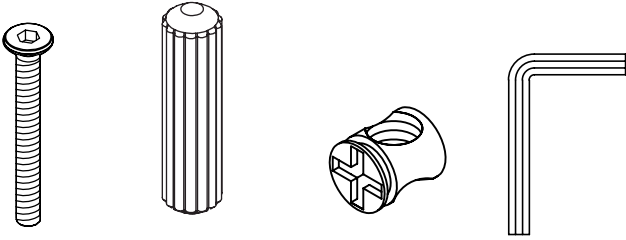

x4 TUD0043 x4 TUD0030 x4 TUD0048 x1 TUD0026

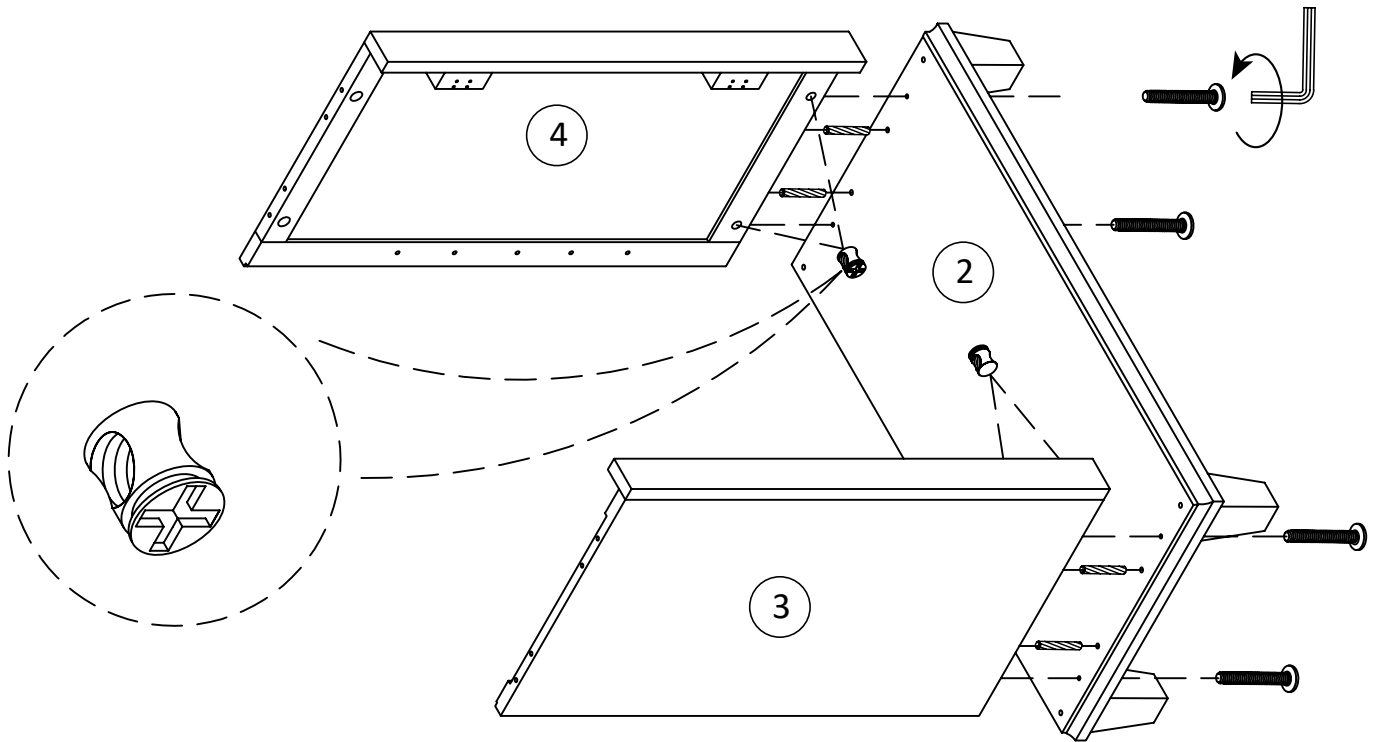

* raw edges are shaded

Step 3

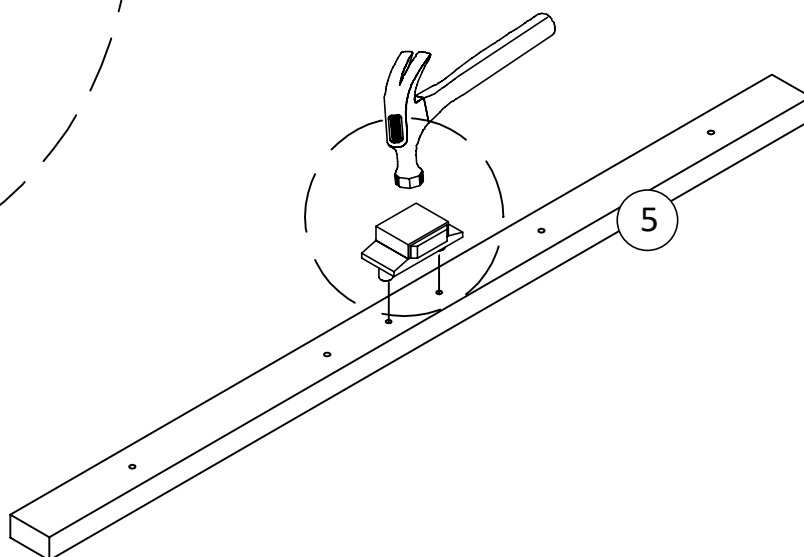
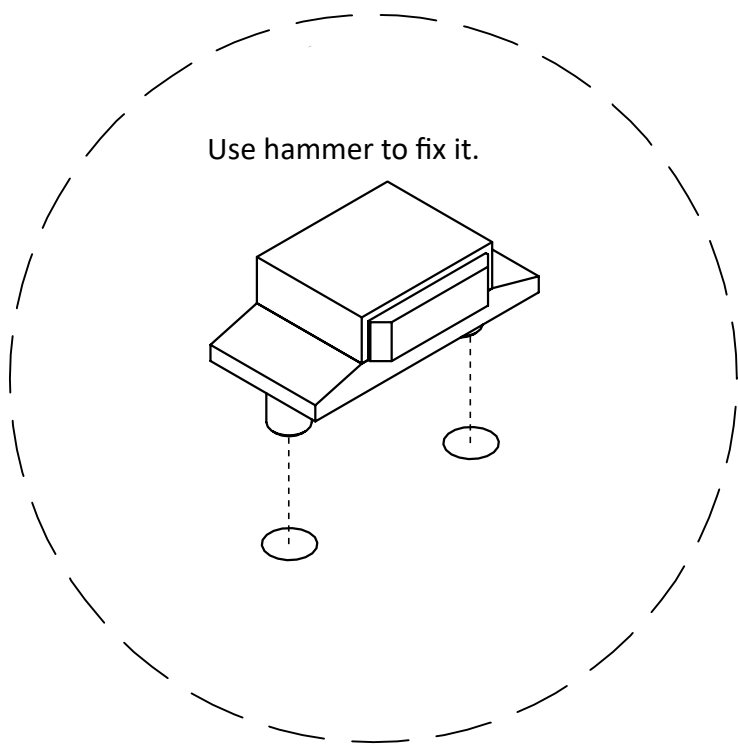
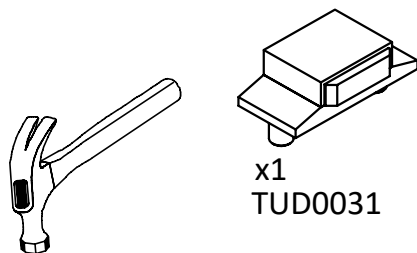

* raw edges are shaded

Step 4

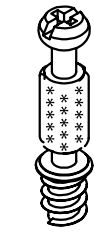
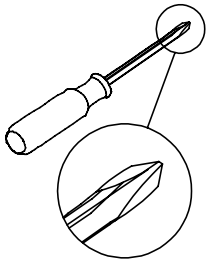

x4
TUD0001

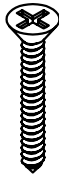

x4
TUD0022

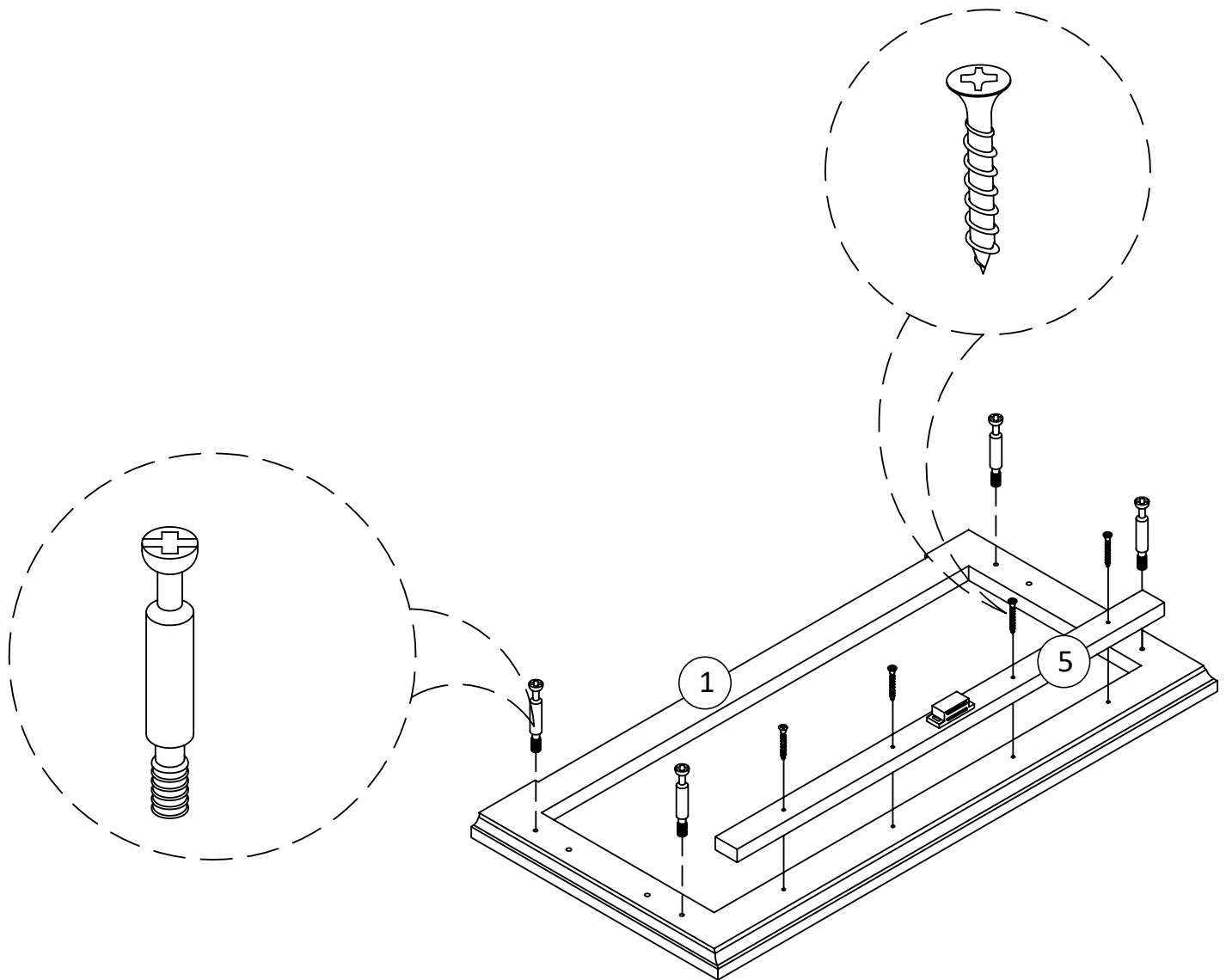

* raw edges are shaded

Step 5

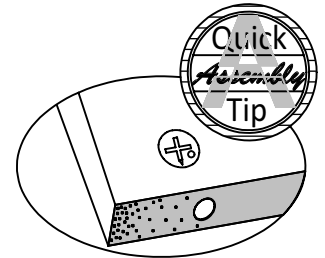
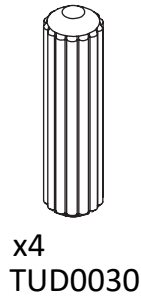
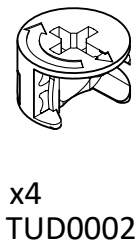
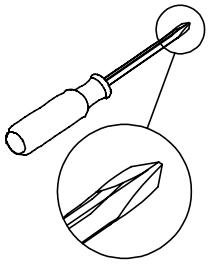

Proper orientation of CAM LOCK

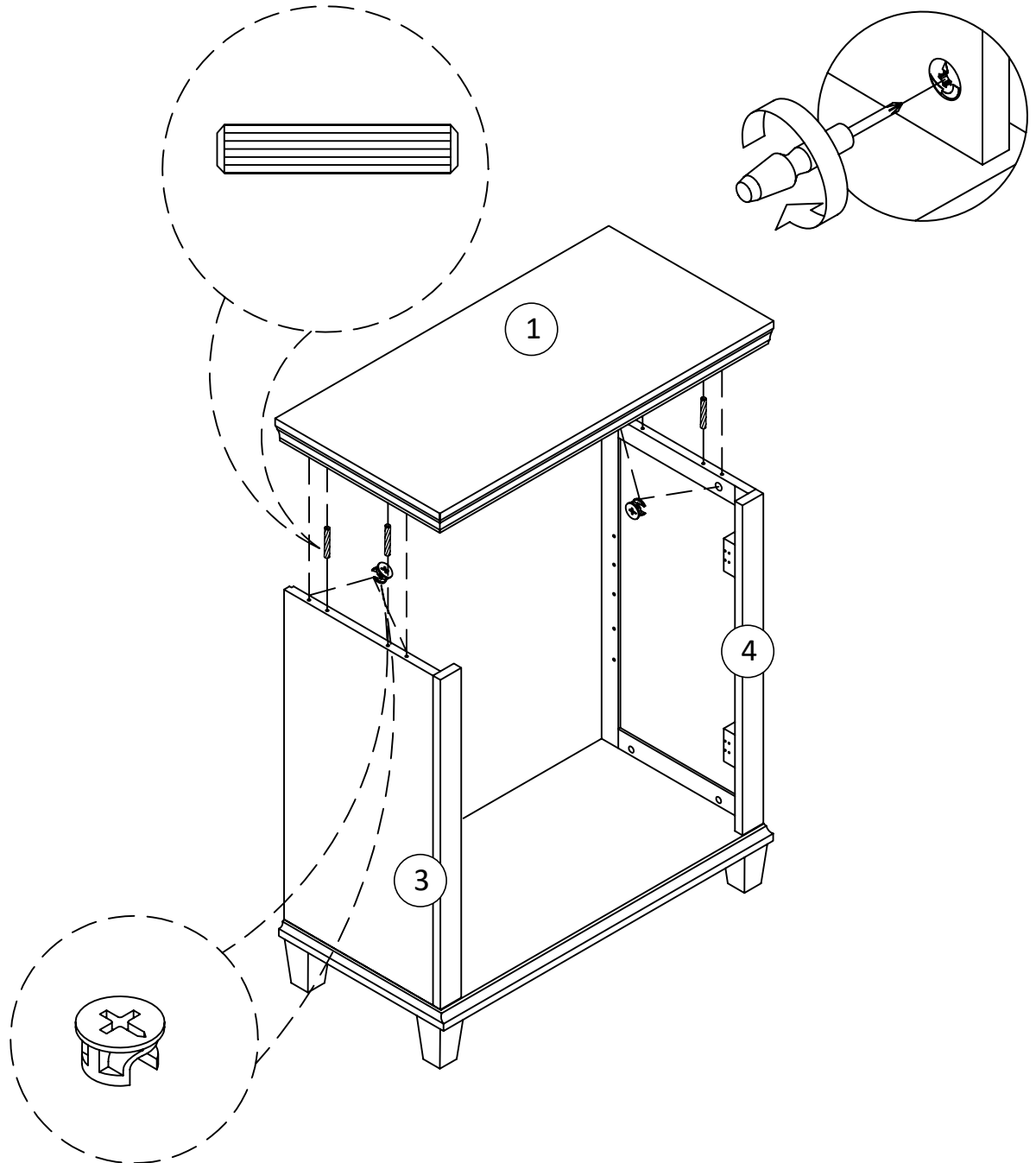

* raw edges are shaded

Step 6

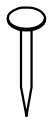
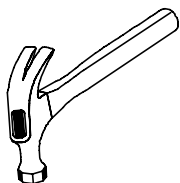

x16
TUD0006

Attached back panel as shown.
Ensure that the unit is square.
Distance from corner to corner must be equal as shown.

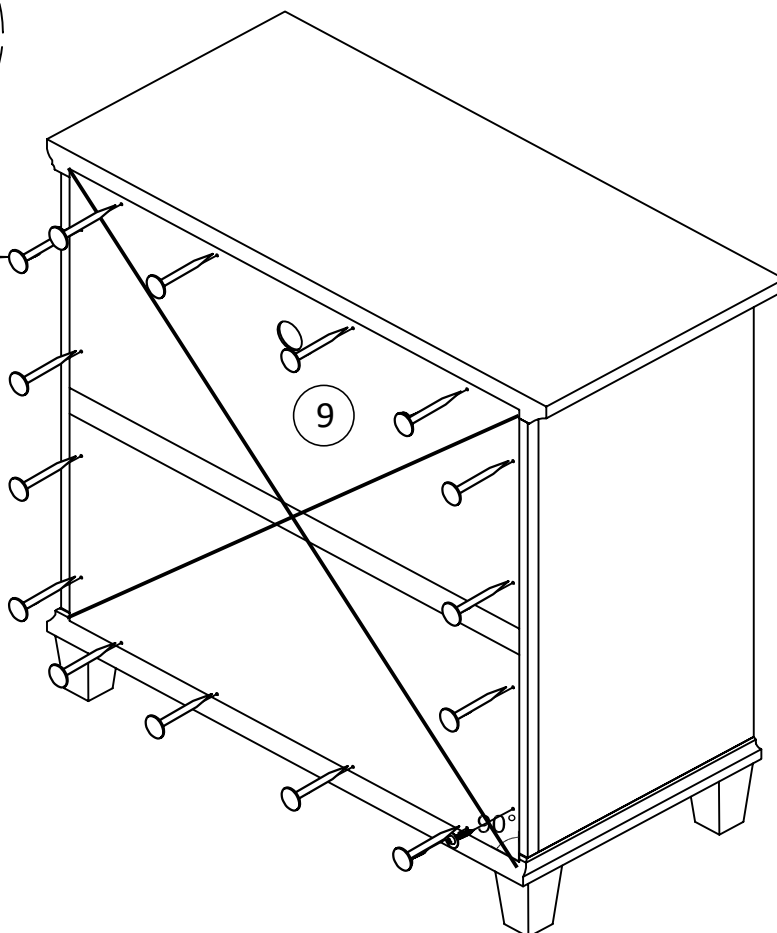
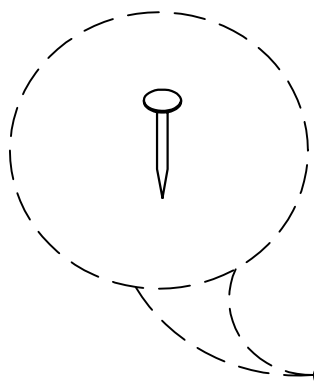

* raw edges are shaded

Step 7



x8
TUD0018

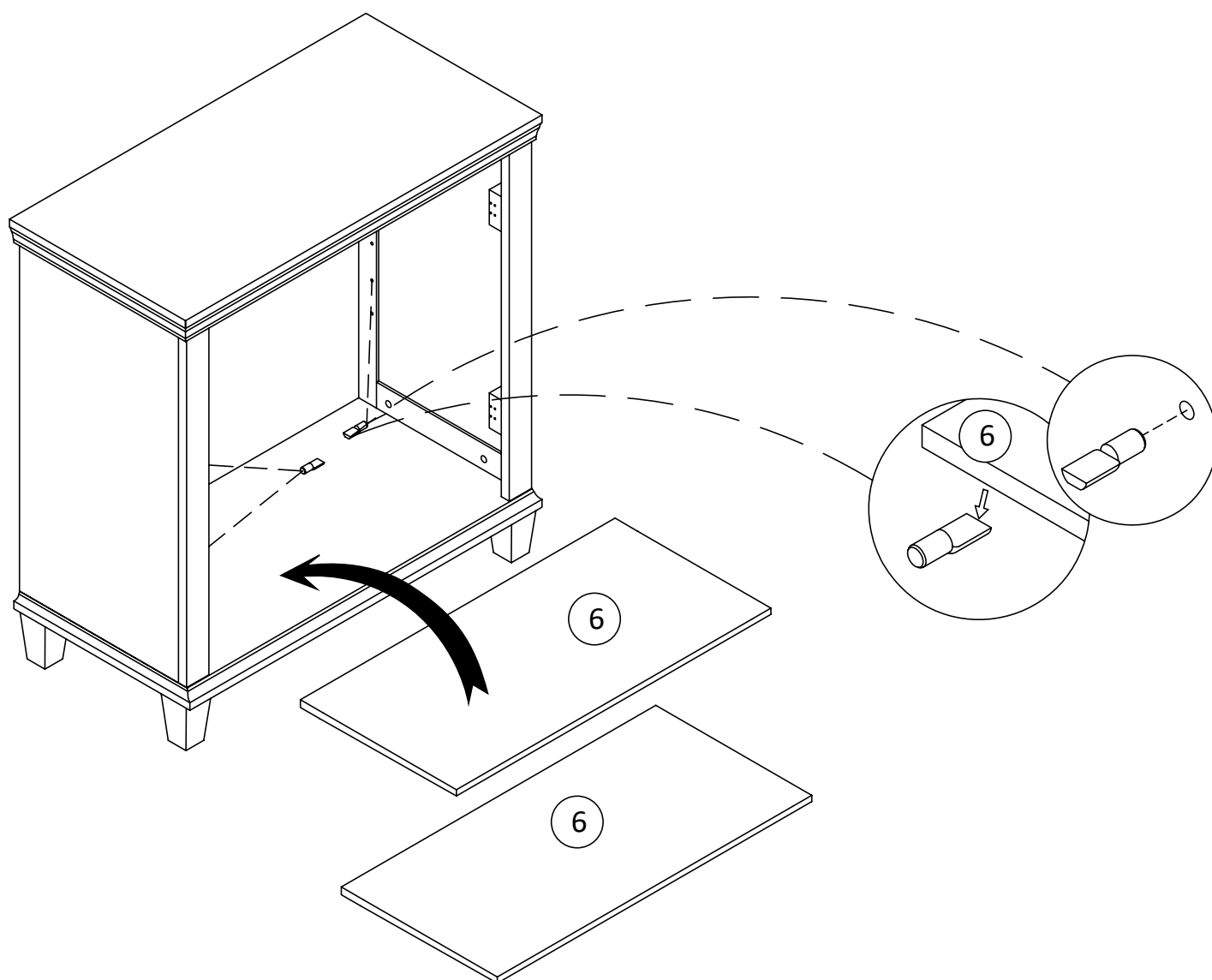

* raw edges are shaded

Step 8

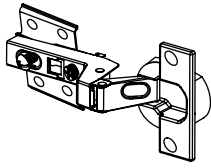
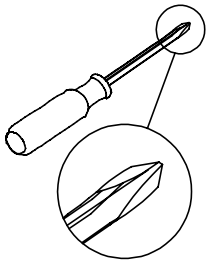

x4
TUD0037

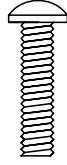

x2
TUD0010



x2
TUD0066



x2
TUD0031

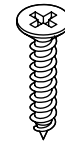

x24
TUD0008

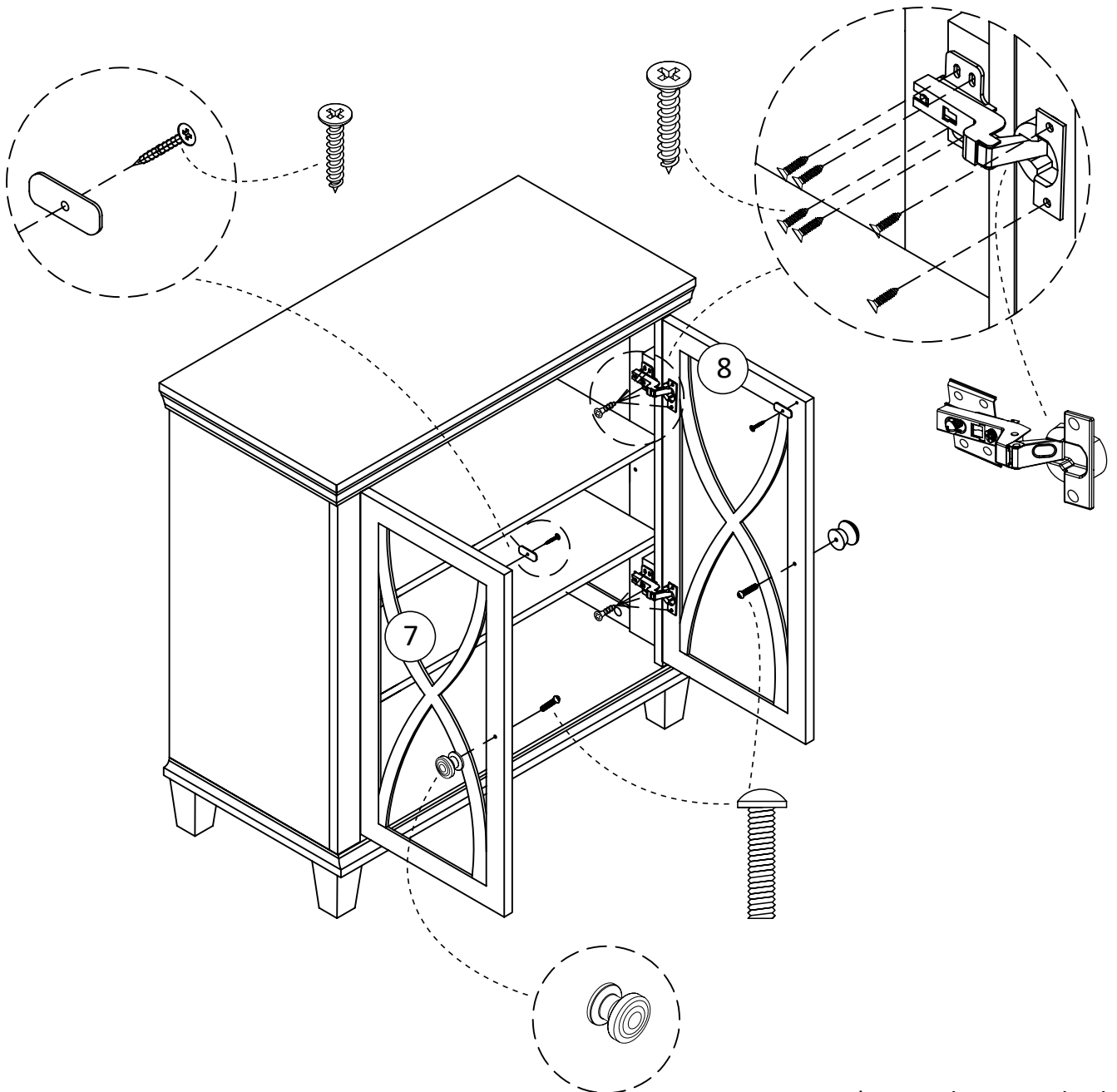

* raw edges are shaded

Step 9

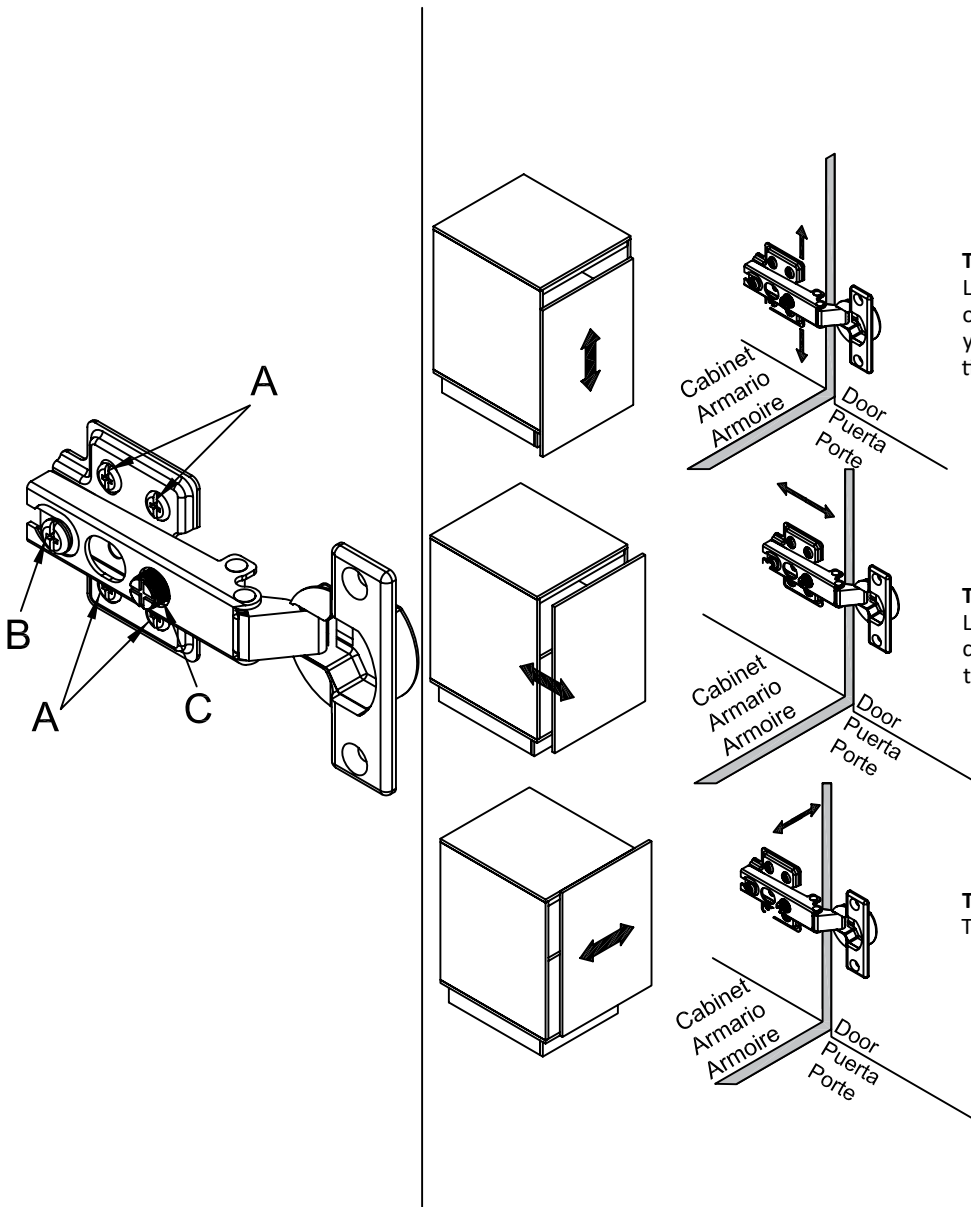

To adjust the vertical height.

Loosen the four screws "A" on both hinges. Two of them are usually in slotted holes which allows you to adjust up or down by a few milimeter. Then tighten back up.

To adjust depth.

Loosen screw "B" and adjust door, if the door cannot be adjusted, please loosen screw "C", then try again. Tighten screw "B" and "C".

To adjust side ways.

Turning the screw "C" on BOTH hinges on each door.

* raw edges are shaded

Maximum Loads

This unit has been designed to support the maximum loads shown. Exceeding these load limits could cause sagging, instability, product collapse, and/or serious injury.

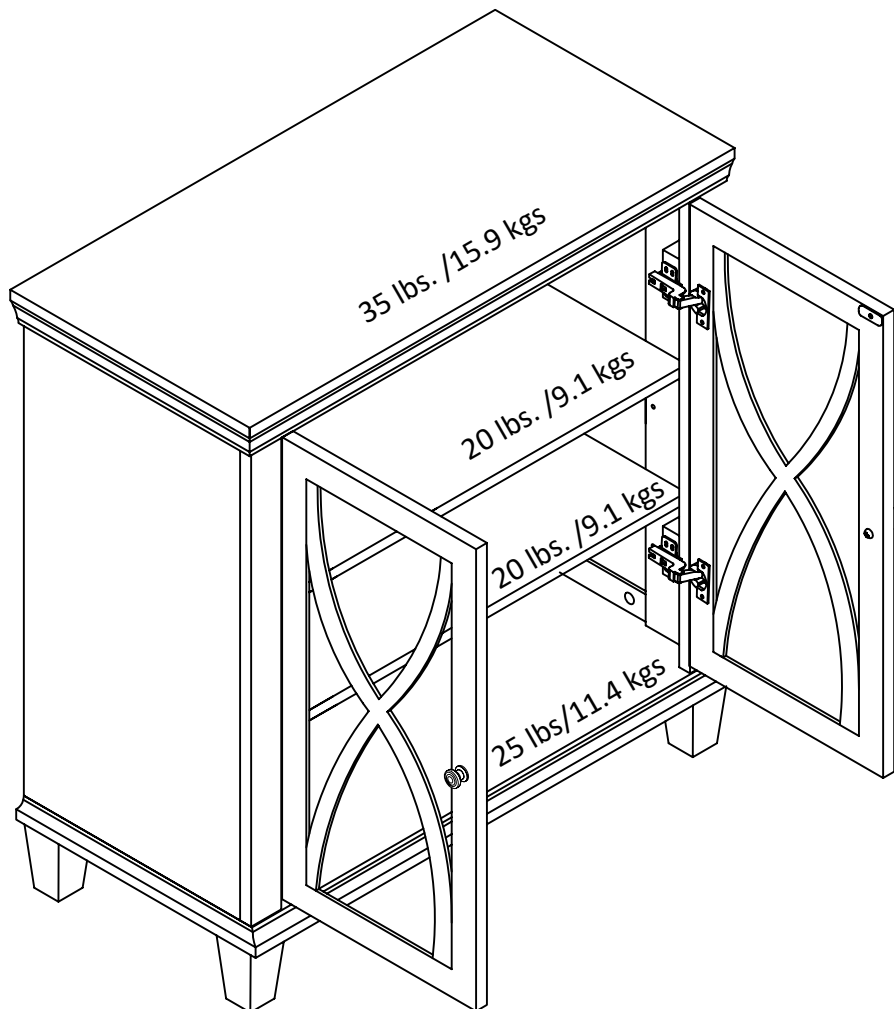

Warning: Risk of serious injury to person - do not place a television on this furniture. This furniture is not approved for use with a television.

Certificate of Conformity

1. This certificate applies to Dorel Home Furnishings, Inc. product identified by this instruction manual.
2. This certificate applies to compliance of this product with the CPSC Ban on Lead-Containing Paint (16 CFR 1303).
3. This product is distributed by: Dorel Home Furnishings Europe Ltd.
Building 4, Imperial Place, Maxwell Road,
Borehamwood WD6 1JN, United Kingdom
+01942 524100 - cseurope@dorel.com
4. Site of Manufacturer: Muar, Malaysia.
5. See front page of instruction manual for date of manufacturer.

Register your product to receive the following:



- * New trend details -sneak peek on what's new
- * Surveys -have a voice within our community
- * Exclusive deals and discount codes
- * Quick and easy replacement part service

To register your product, visit Ameriwoodhome.com

5 Star Rating



Visit your local retailer's website, rate your purchased product and leave us some feedback!

We would like to extend a big "Thank You" to all of our customers for taking the time to assemble this Ameriwood Home product, and to give us your valuable feedback

*Thank
You!*

Cubierta Delantera

Este libro de instrucciones contiene información **IMPORTANTE** de seguridad. Por favor lea y manténgalo para referencia en el futuro.

No Regrese este producto! Comuníquese con nuestro amigable equipo de servicio al cliente para obtener ayuda.

Llámenos al: 1-800-489-3351 (Gratis) Lunes - Viernes 9am - 5pm CST

Visitar: www.ameriwoodhome.com

PRECAUCION

Este mueble puede volcarse y causar graves heridas y/o muerte.

Anclar el mueble a un poste de madera en la pared (si esto se requiere).

No Permita que los niños monten el mueble.

Mantenga los artículos más pesados en los cajones de abajo.

Consejos Útiles (página 2)

- Abra su artículo en el área donde usted planea utilizarlo para evitar levantar y moverlo menos
- Identificar, ordenar y contar las piezas antes de intentar ensamblar
- Las clavijas de compresión se golpean con un martillo
- Las diapositivas están marcadas con una R (derecha) y L (izquierda) para la colocación correcta
- Asegúrese de que siempre este el punto localizado en la parte superior de bloqueador de leva este volteado hacia borde exterior
- Utilizar todos los clavos para el panel de atrás y distribuirlos por igual
- El panel de atrás debe utilizarse para asegurarse de que la unidad quede fija y firme
- No use químicos fuertes ni limpiadores abrasivos en este artículo
- Nunca empuje, tire ni arrastre los muebles

Antes de Que Empieces (página 3)

- Lea cuidadosamente cada paso y siga el orden correcto
- Separar y contar todas sus piezas y hardware
- Dése suficiente espacio para el proceso de ensamble
- Tenga las siguientes herramientas: destornillador de cabeza plana, #2 cabeza Phillips Destornillador y martillo
- Precaución: Si usa un taladro electrónico o un destornillador eléctrico para atornillar, por favor asegúrese que deje de atornillar cuando el tornillo este apretado. Fallar hacer esto puede causar barrer el tornillo

Sistema de fijar el bloqueo de leva (página 3)

Este sistema de fijar el bloqueo de leva sera usado en todo el proceso ensamble

Identificación de la Junta (página 4&5)

Tamaño no real

Lista de (página 6)

Tamaño no real

Página 8

Usa un martillo para arreglarlo.

Página 11

Panel posterior adjunto como se muestra. Asegúrese de que la unidad sea cuadrada. La distancia de esquina a esquina debe ser igual como se muestra.

Página 14

Para ajustar la altura vertical.

Afloje los cuatro tornillos "A" en ambas bisagras. Dos de ellos generalmente están en agujeros ranurados que le permiten ajustar hacia arriba o hacia abajo unos pocos milímetros. Luego apriete nuevamente.

Para ajustar la profundidad.

Afloje el tornillo "B" y ajuste la puerta, si la puerta no se puede ajustar, afloje el tornillo "C", luego intente nuevamente. Apriete los tornillos "B" y "C".

Para ajustar las vías laterales.

Girando el tornillo "C" en AMBAS bisagras en cada puerta.

Página 15

CARGA MAXIMA

Esta unidad ha sido diseñada para soportar la carga máxima anotada. El exceder estos límites puede causar inestabilidad, colapsarse y/o causar serias lesiones.

ADVERTENCIA: Riesgo de lesiones a las personas - no coloque un televisor sobre muebles.

Este mueble no está aprobado para su uso con un televisor.

Página 16

Registre su producto para recibir lo siguiente:

- * Nuevos detalles sobre las tendencias - Sneek echa un vistazo a lo nuevo
 - * Encuestas - tener una voz dentro de nuestra comunidad
 - * Ofertas exclusivas y códigos de descuento
- Servicio de piezas de repuesto rápido y fácil

Para registrar su producto, visite Ameriwoodhome.com

5 estrellas

Visite el sitio web de su distribuidor local, califique su producto comprado y déjenos algunos comentarios!

Nos gustaría extender un gran "Gracias" a todos nuestros clientes por tomarse el tiempo para montar este producto Ameriwood Home, y para darnos sus valiosos comentarios

Gracias!

Capot avant

Ce livret d'instructions contient d'importantes informations de sécurité. S'il vous plaît lire et conserver pour référence ultérieure.

Ne pas retourner ce produit! Contactez notre équipe de service à la clientèle amical pour aider.

Appel: 1-800-489-3351 (gratuit) Lundi - Vendredi 9am - 5pm CST

Visite: www.ameriwoodhome.com

MISE EN GARDE

Ce mobilier peut basculer et causer des blessures graves et / ou la mort.

Ancrer les meubles à un poteau en bois sur le mur (si cela est nécessaire).

Ne laissez pas les enfants monter l'armoire.

Gardez les articles plus lourds dans les tiroirs ci-dessous.

Conseil (page 2)

- Ouvrez votre article dans la zone où vous prévoyez de l'utiliser pour éviter de soulever et déplacer moins
- Identifier, trier et compter les pièces avant de monter
- bouchons de compression sont frappés avec un marteau
- Les lames sont marqués par un R (droite) et L (à gauche) pour le positionnement correct
- Assurez-vous toujours ce point, je Aviana sur le dessus de la came de blocage ce bord extérieur volteadohacia
- Utilisez tous les clous du panneau arrière et les distribuer également
- Le panneau arrière doit être utilisé pour faire en sorte que l'unité est fixe et ferme
- Ne pas utiliser de produits chimiques ou de produits abrasifs sur cet article
- Ne jamais pousser, tirer ou meubles de glisser

Avant de commencer (page 3)

-Lire attentivement chaque étape et suivre l'ordre

-separate et compter toutes les pièces et matériel

-Dése un espace suffisant pour le processus d'assemblage

-Soyez les outils suivants: tournevis Phillips n ° 2 tête

Tournevis et un marteau

-Precaución: Si vous utilisez une perceuse électronique ou un tournevis électrique à vis, s'il vous plaît faire arrêter le vissage lorsque le tonillos ce serré. Le non-respect cela peut provoquer balayer la vis

Système de régler le verrou de came (page 3)

Ce système de fixation du verrou de came sera utilisé tout au long du processus d'assemblage

Identification du Conseil (page 4 et 5)

pas la taille réelle

Liste (page 6)

pas la taille réelle

page 8

Utilisez un marteau pour le réparer.

page 11

Panneau arrière attaché comme indiqué.

Assurez-vous que l'unité est carrée.

La distance entre les coins doit être égale comme indiqué.

page 14

Pour ajuster la hauteur verticale.

Desserrez les quatre vis «A» sur les deux charnières. Deux d'entre eux sont généralement dans des trous oblongs, ce qui vous permet d'ajuster quelques millimètres vers le haut ou le bas. Puis resserrer.

Pour ajuster la profondeur.

Desserrez la vis "B" et ajustez la porte. Si la porte ne peut pas être ajustée, veuillez desserrer la vis "C", puis réessayez. Serrer les vis "B" et "C".

Pour ajuster les côtés.

Tourner la vis "C" sur les DEUX charnières de chaque porte.

Fixer le rail avant et arrière en serrant le verrou à came

Page 15

MAXIMUM DE CHARGE

Cet appareil est conçu pour supporter la charge maximale enregistrée. Le dépassement de ces limites peut provoquer l'instabilité, l'effondrement et / ou causer des blessures graves.

AVERTISSEMENT: Risque de blessures aux personnes - ne placez pas la télévision sur les meubles.

Ce mobilier est pas approuvé pour une utilisation avec une télévision.

Page 16

Enregistrez votre produit pour recevoir les éléments suivants:

- * De nouveaux détails sur les tendances - Sneek vérifier la nouvelle
 - * Sondages - ont une voix dans notre communauté
 - * Offres exclusives et des codes de réduction
- Service de pièces de rechange rapide et facile

Pour enregistrer votre produit, visitez Ameriwoodhome.com

5 étoiles

Visitez le site Web de votre distributeur local, classez votre produit acheté et laissez des commentaires!

Nous aimerions étendre un grand "Merci" à tous nos clients pour prendre le temps de rassembler ce produit Ameriwood Home et de nous faire part de vos précieux commentaires

Merci!