

Service • Assistenza • Dienstverlening • Serwis Servis • Szerviz • Сервисная служба	
Name • Nom • Nome • Naam • Nazwa • Jméno • Názov • Név • Denumire • İsim • Название	PEVENSEY
Nr. • No. • N° • Номер • Č • Sz	
Typ • Type • Тип • Típus • Тиро • Тип	
	
	

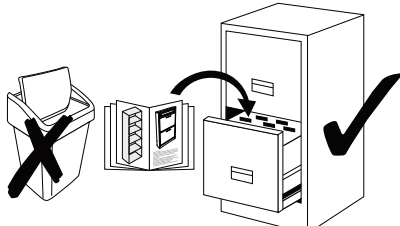
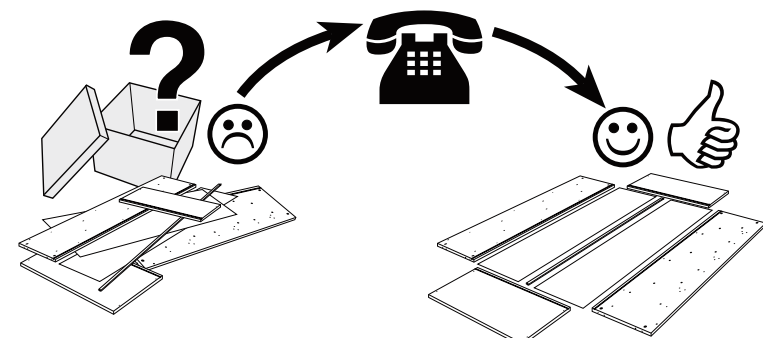
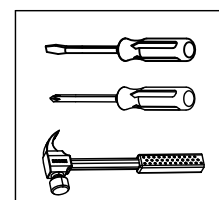
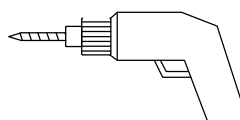
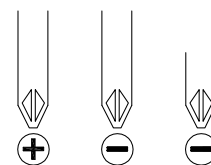
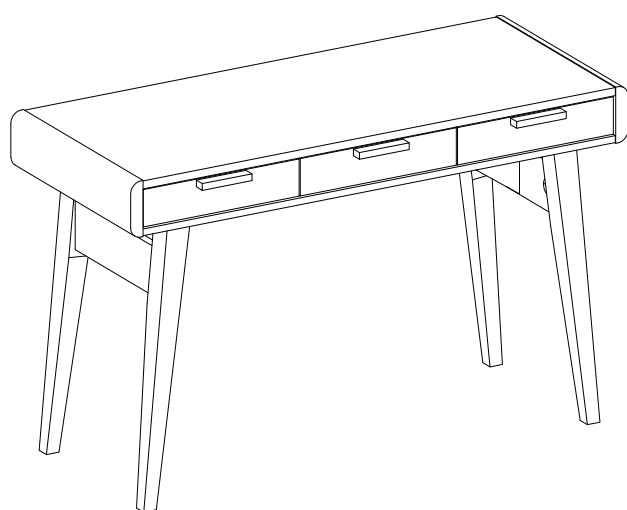

**(D)** Montageanleitung

**(GB)** Assembly instructions

**(FR)** Notice de montage

**(IT)** Istruzioni di montaggio

**(NL)** Handleiding voor de montage

**(PL)** Instrukcja montażu

**(CZ)** Montážní návod

**(SK)** Návod na montáž

**(HU)** Szerelési útmutató

**(ES)** Instrucciones de montaje

**(TR)** Montaj talimati

**(RU)** Инструкция по монтажу

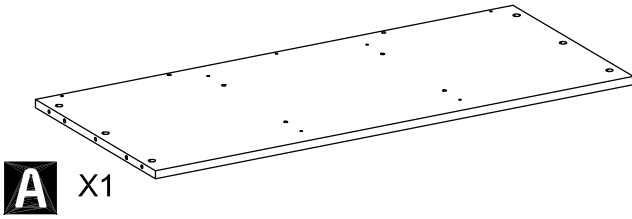
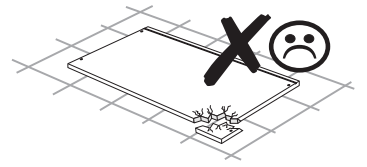
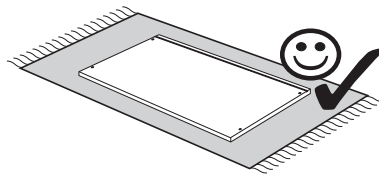
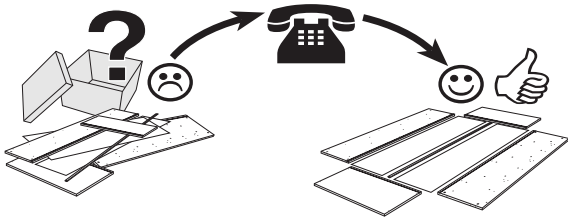

**A** X1

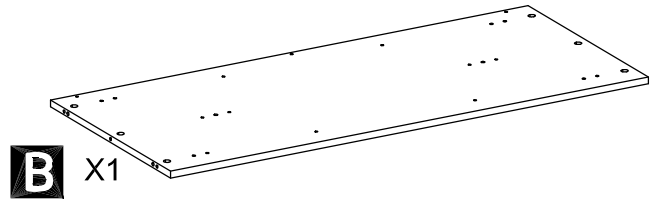

**B** X1

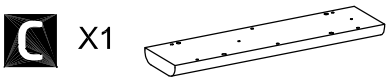

**C** X1

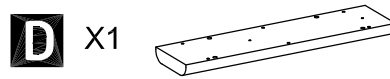

**D** X1

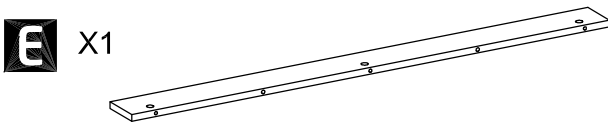

**E** X1

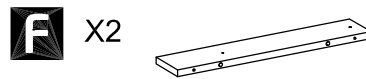

**F** X2

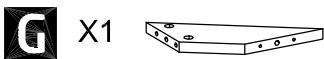

**G** X1

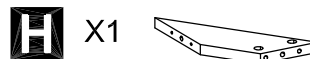

**H** X1



**I** X2

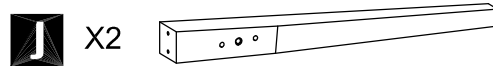

**J** X2

**K** X2

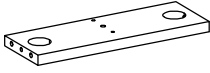

**L** X3

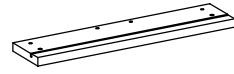

**M** X3



**N** X3



**O** X3



**P** X3

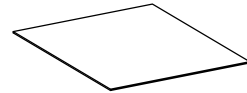

**Q** X3



**R** X29

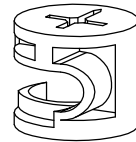

**S** X29



**T** X25

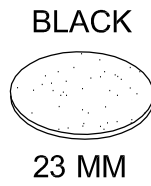

**U** X44

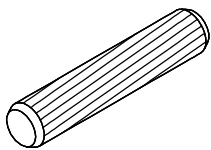

**V** X4



**W** X4

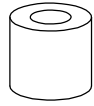

**X** X20



**Y** X1

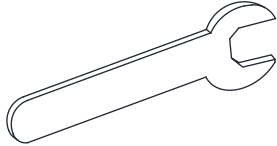

**Z** X4

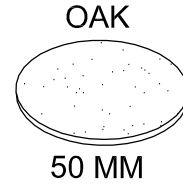

**A1** X4

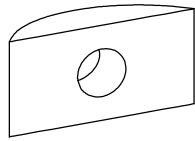

**B1** X4

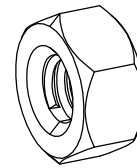

**C1** X4

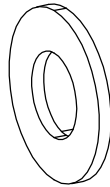

**D1** X6



**E1** X25



**F1** 3set

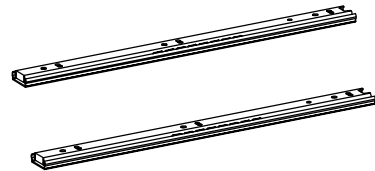

**G1** X4

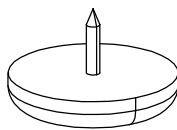

**H1** X4



**I1** X4

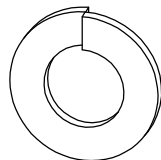

**J1** X4

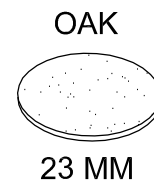

1

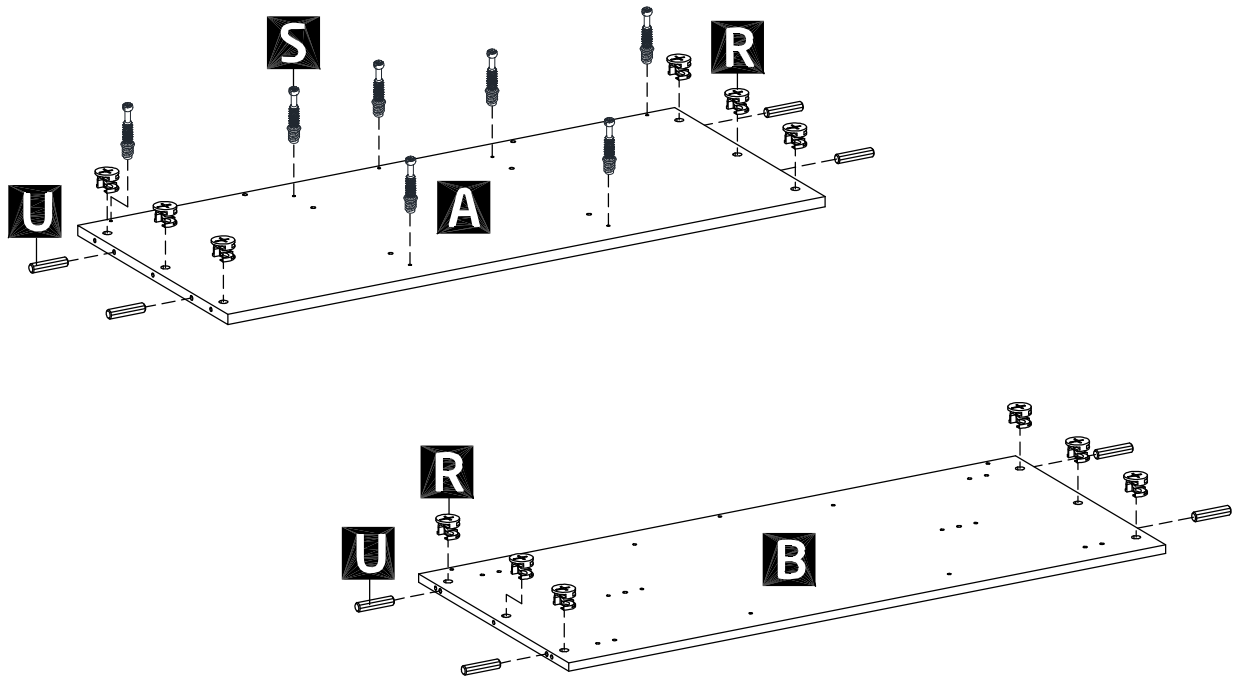

2

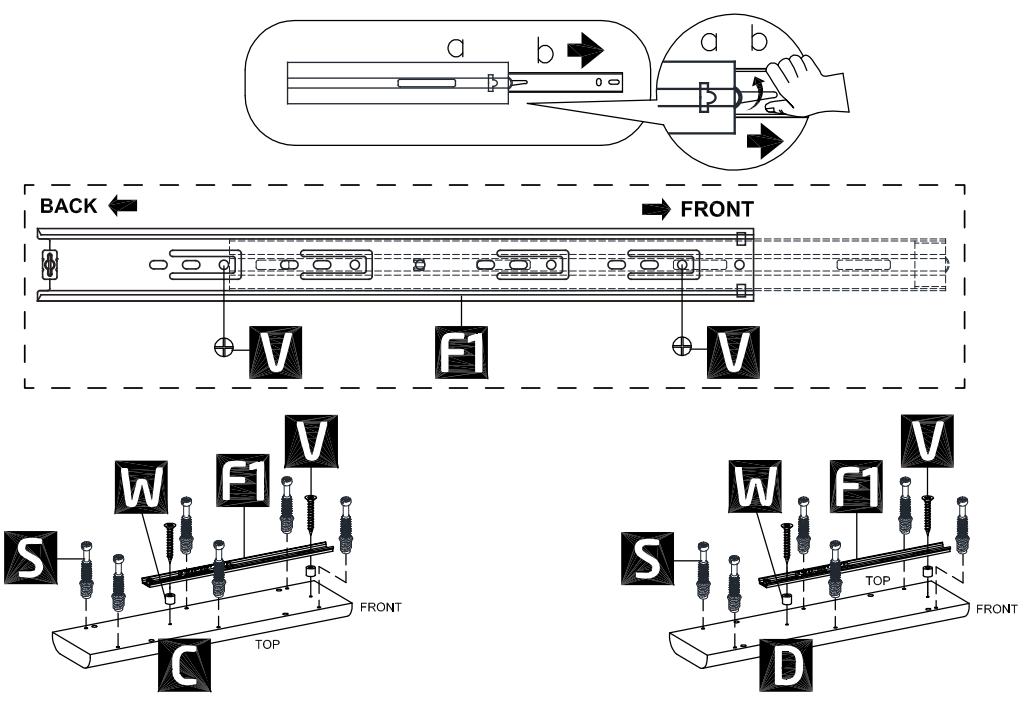

3

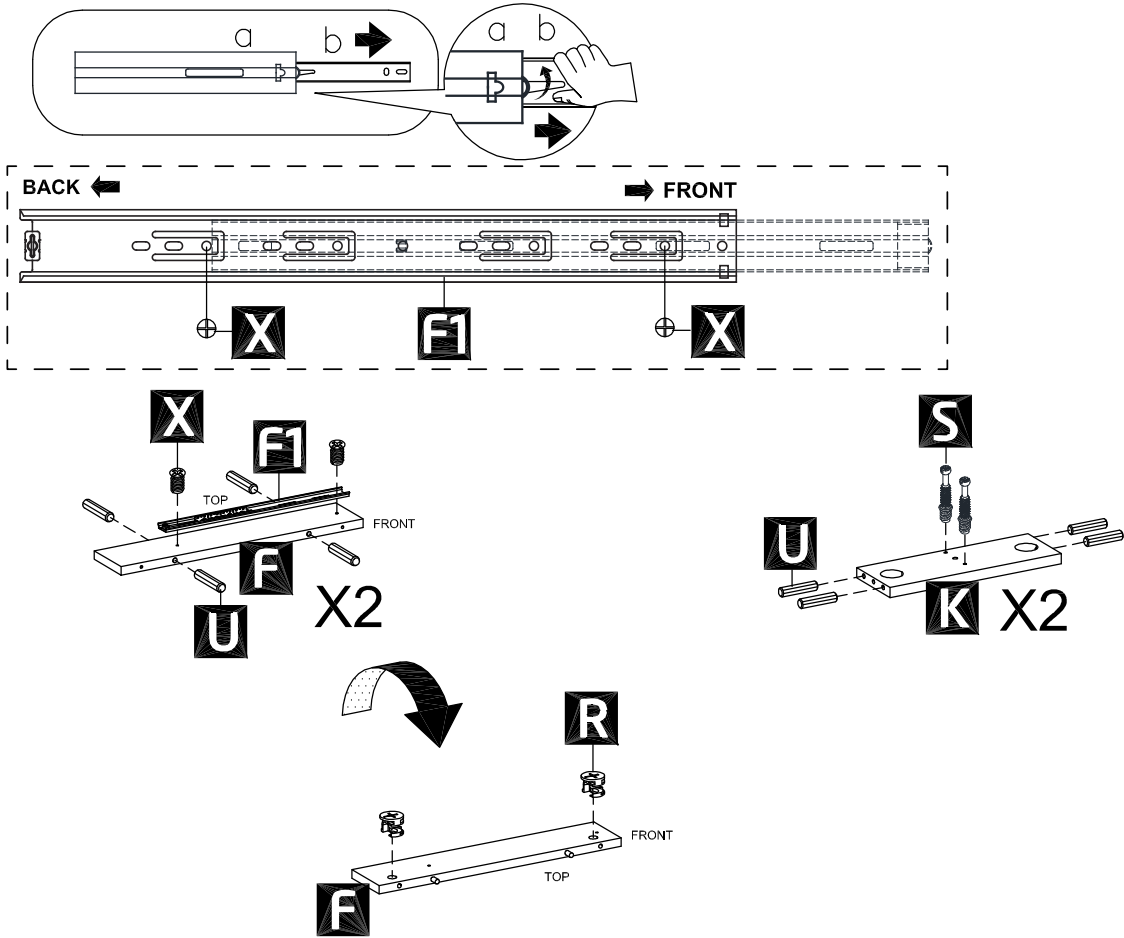

4

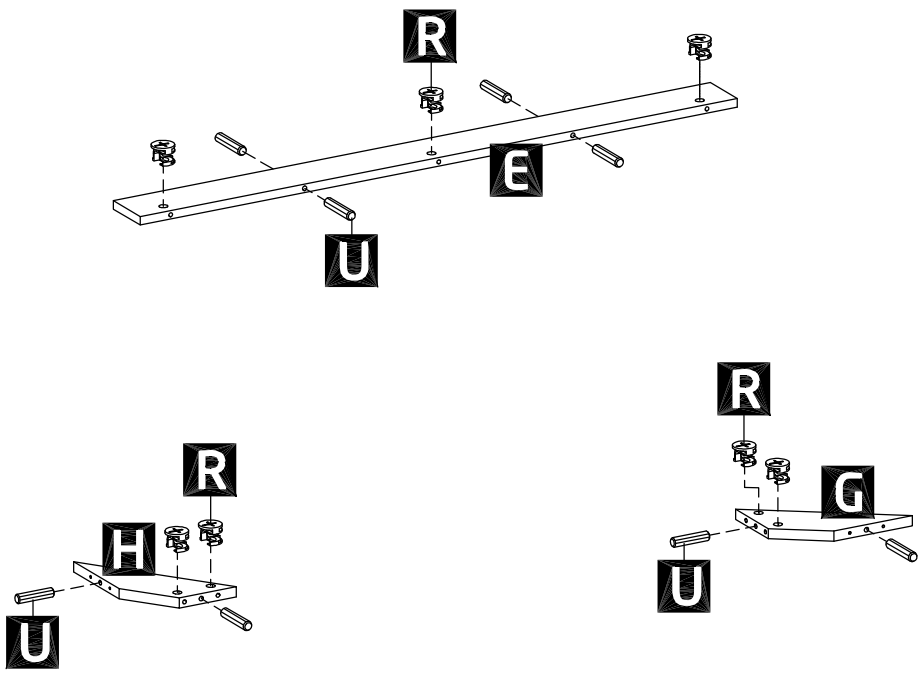

5

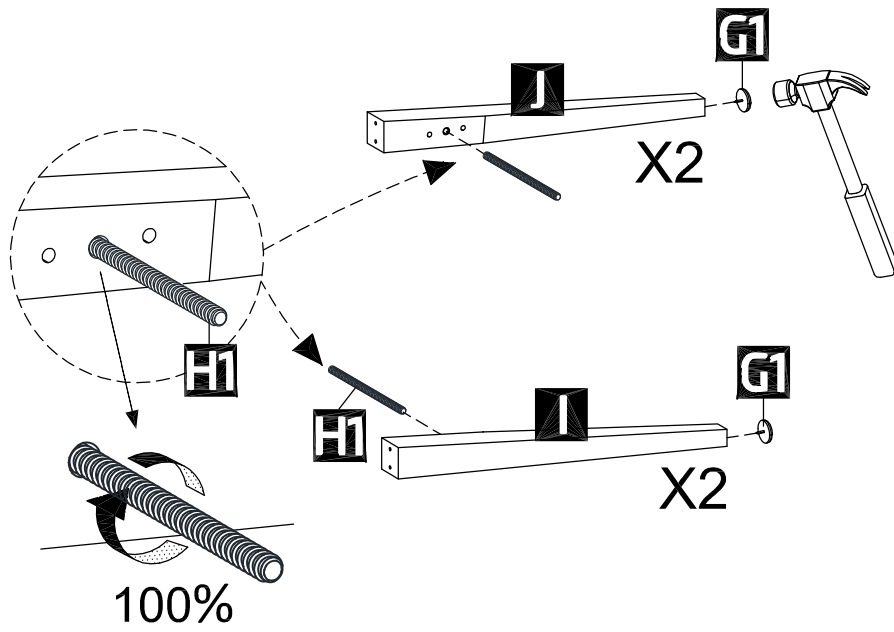

6

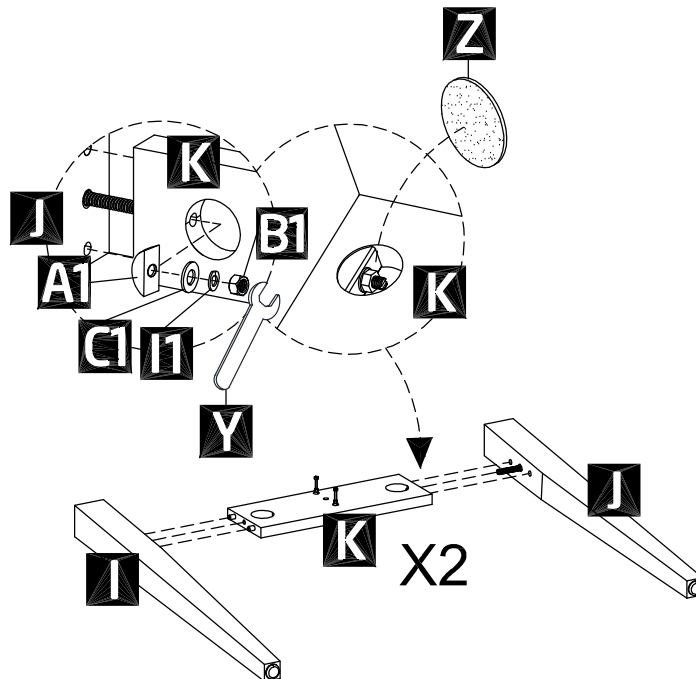

7

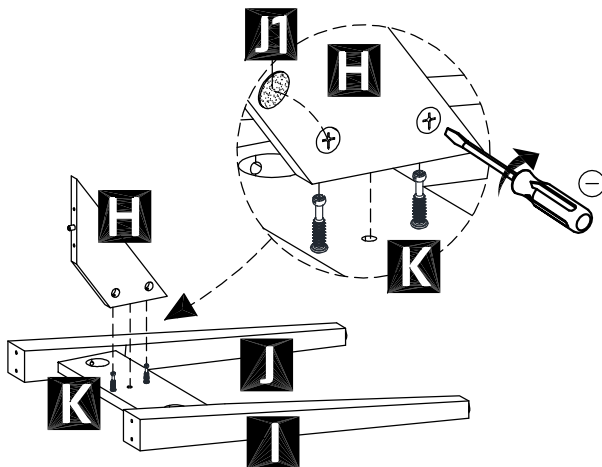

8

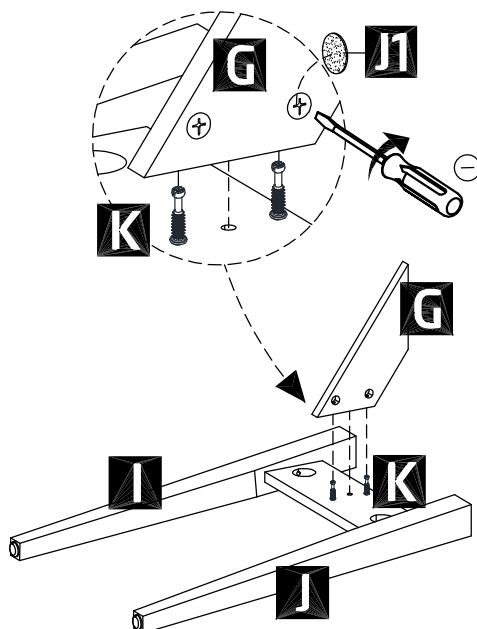

9

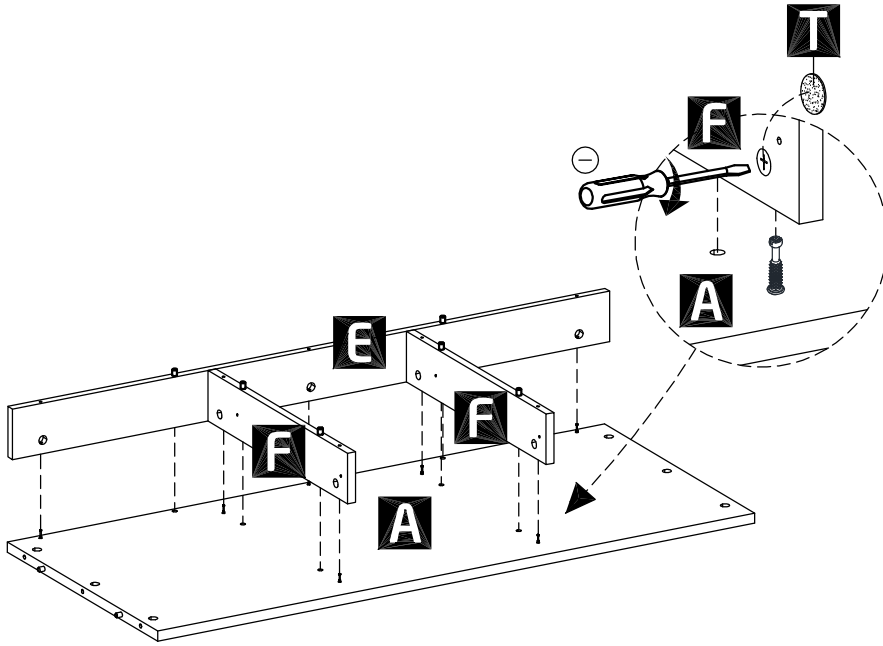

10

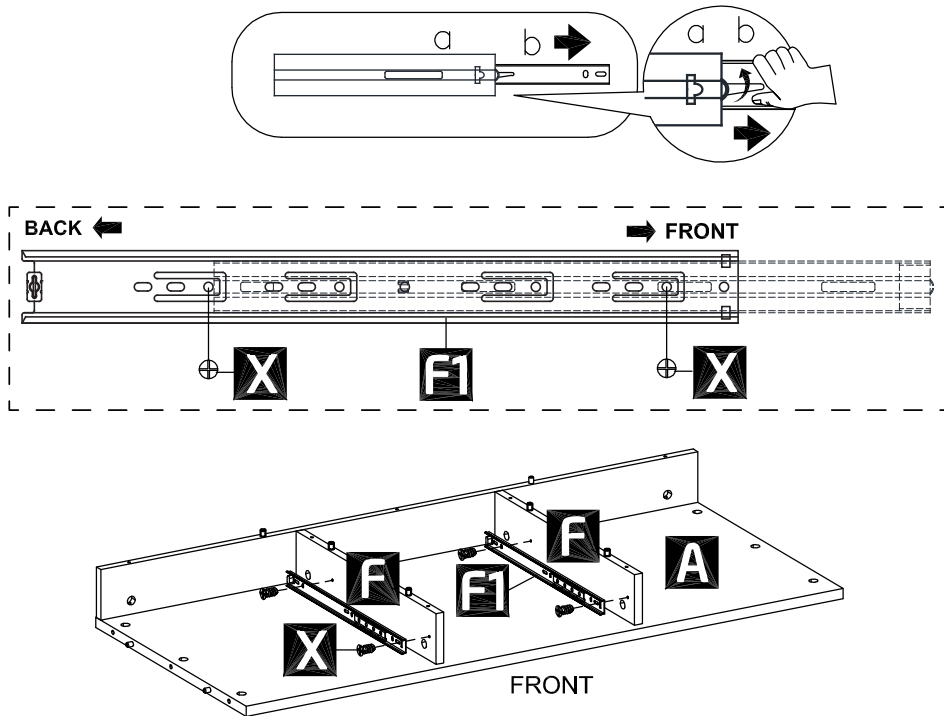

11

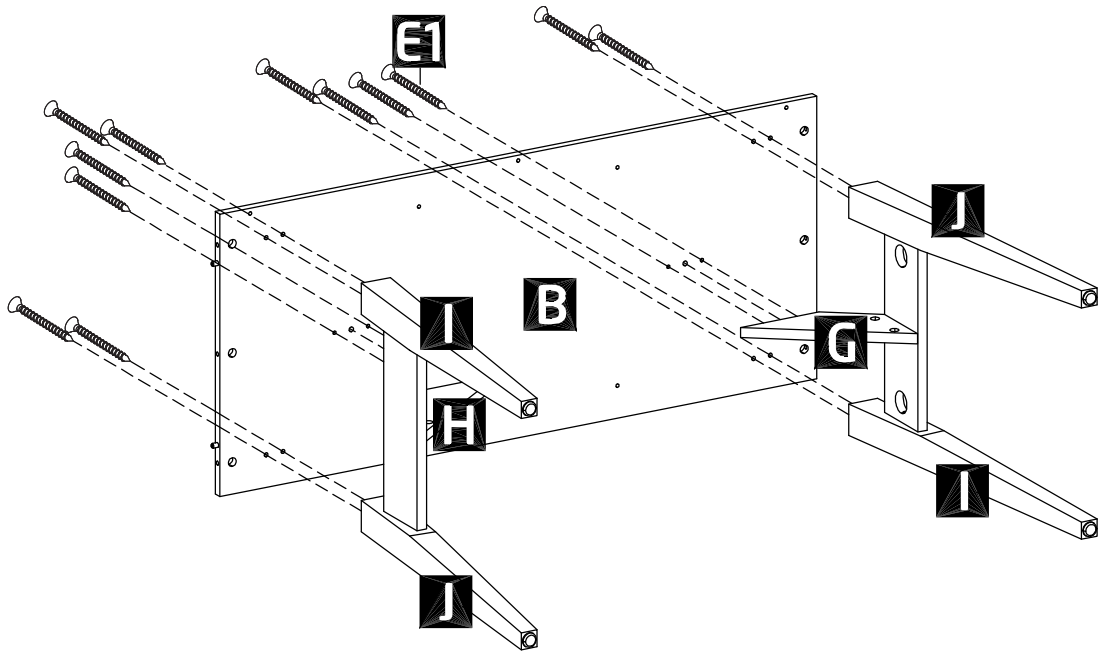

12

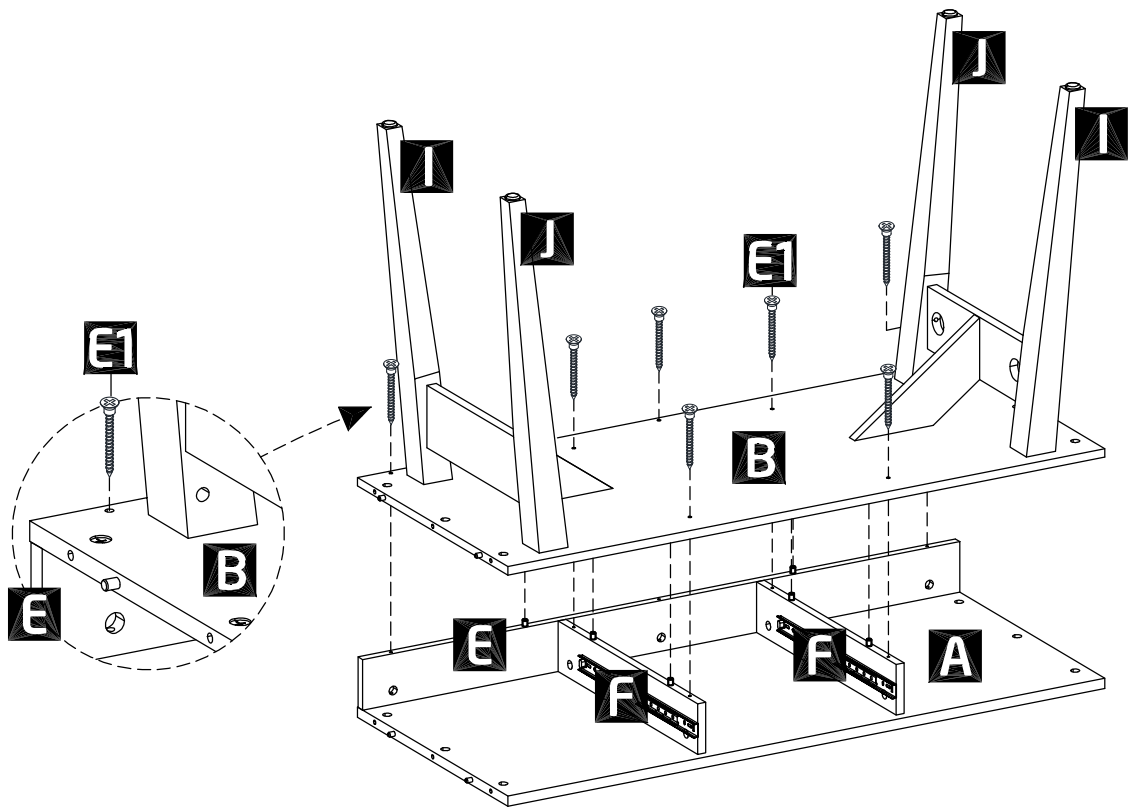

13

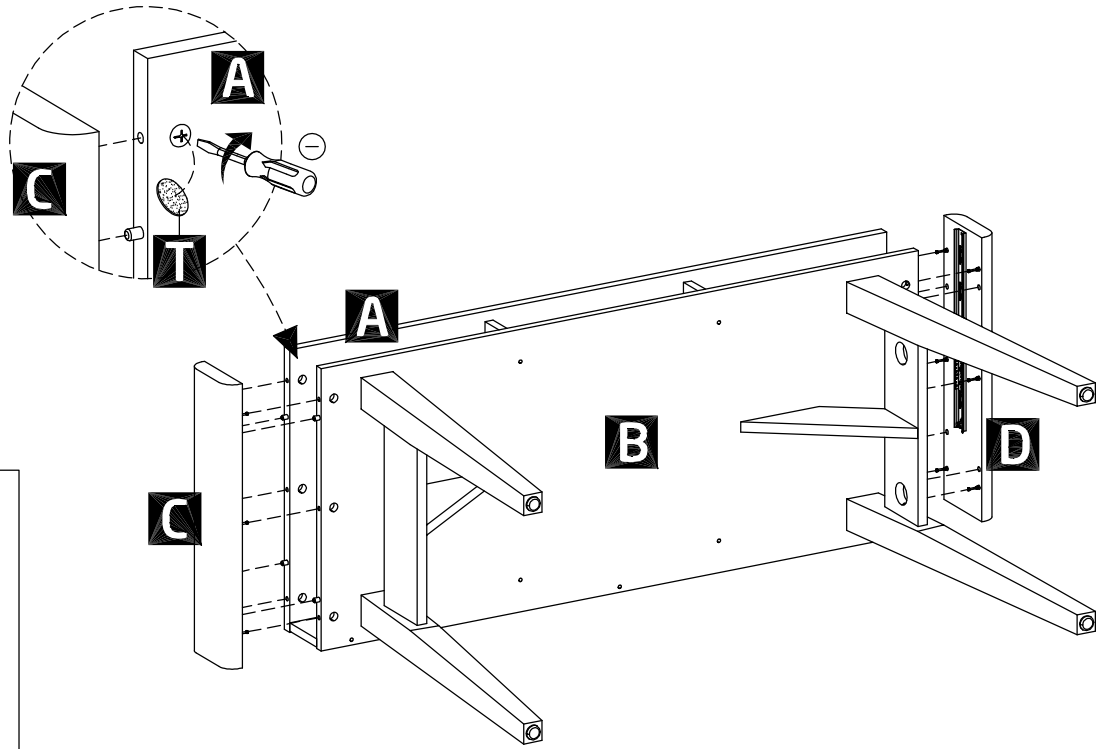

14

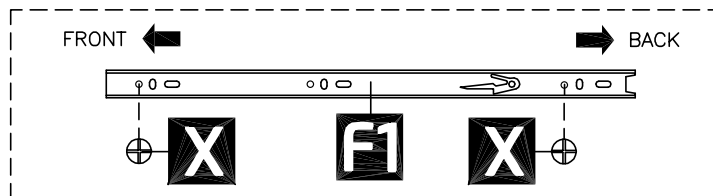
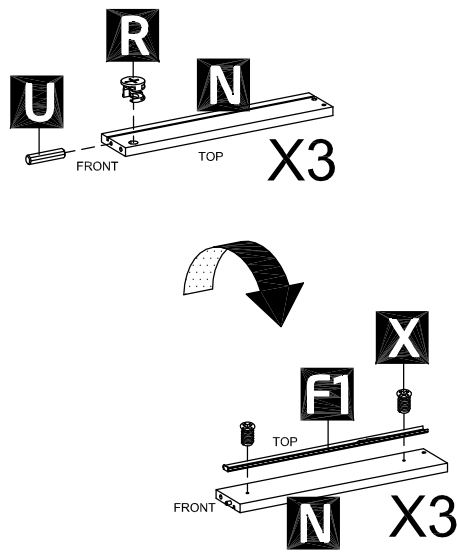

15

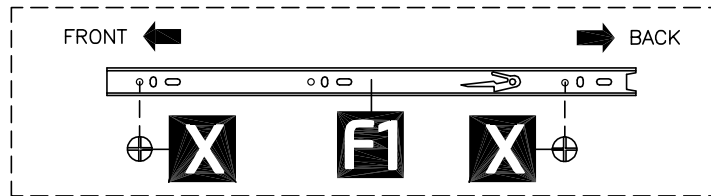
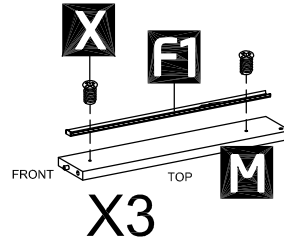
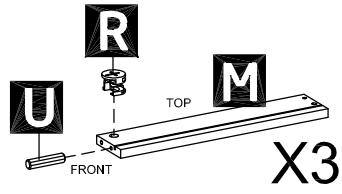

16

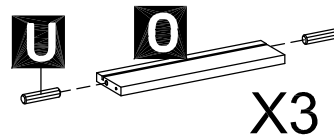
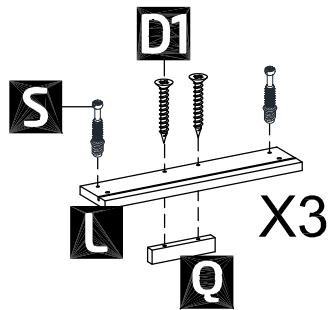

17

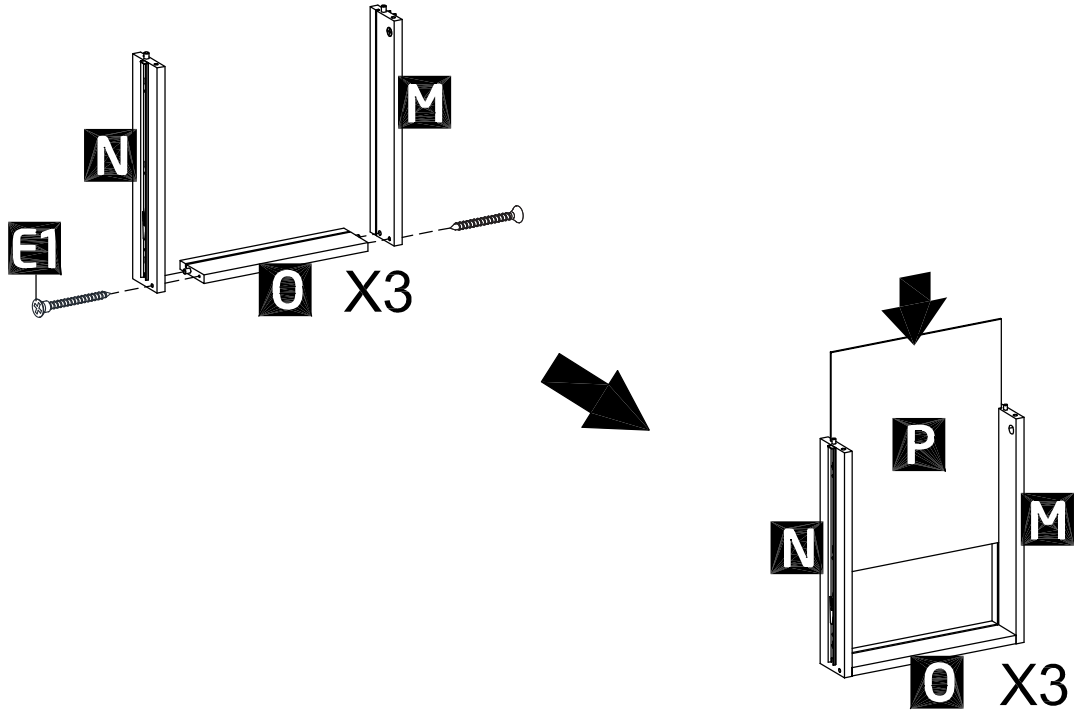

18

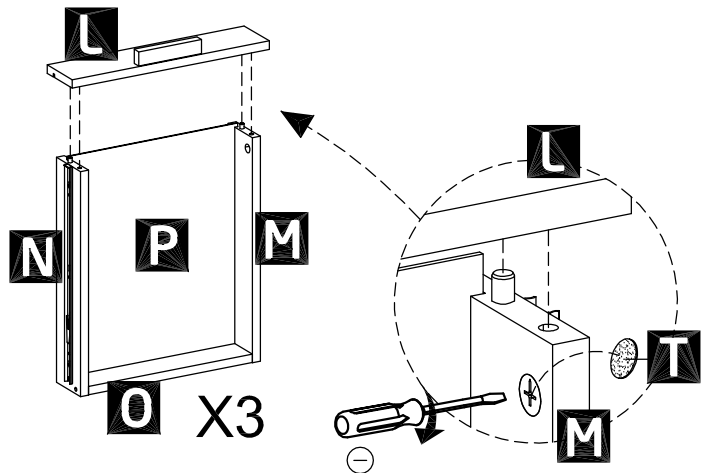

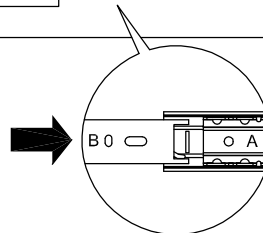
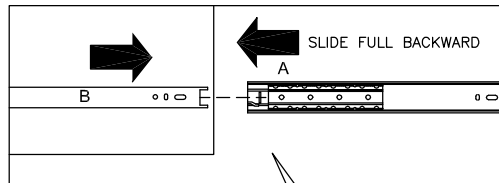
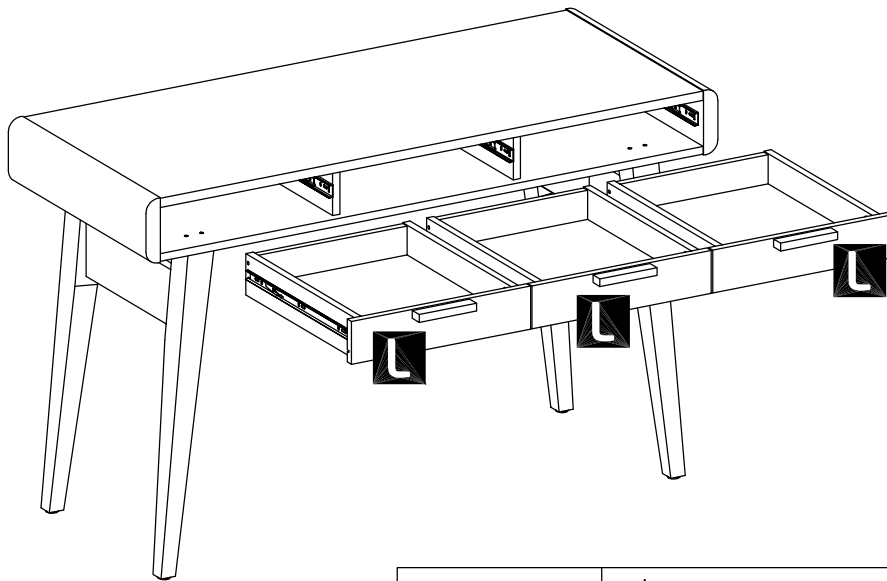



max

30 kg

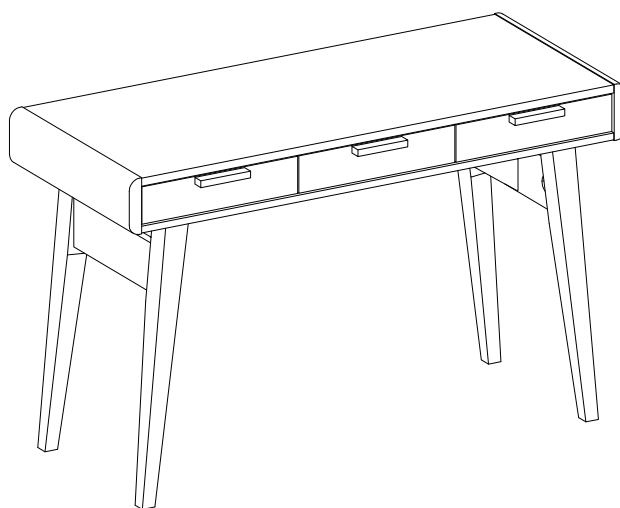

<b>D</b>	Überschreiten Sie die angegebenen Maximalbelastungen nicht. Andernfalls kann das Möbelstück beschädigt oder zerstört werden.
<b>GB</b>	Do not exceed the maximum loads specified. Otherwise, the furniture may sustain damage or be irreparably damaged.
<b>FR</b>	Ne dépassez pas les charges maximum indiquées. Sinon, le meuble peut être endommagé ou détruit.
<b>IT</b>	Non superare il carico massimo indicato. Altrimenti il mobile rischia di rovinarsi o frantumarsi.
<b>NL</b>	Overschrijd de aangegeven maximale belastingen niet. Anders kan het meubelstuk worden beschadigd of vernield.
<b>PL</b>	Nie wolno przekraczać podanych maksymalnych wartości obciążenia. W przeciwnym razie mebel może zostać uszkodzony lub zniszczony.
<b>CZ</b>	Nepřekračujte uvedené maximální zatížení. V opačném případě může dojít k poškození nebo zničení nábytku.
<b>SK</b>	Neprekročte uvedené maximálne zaťaženia. V opačnom prípade sa môže nábytok poškodiť alebo zničiť.
<b>HU</b>	Tartsa be az engedélyezett maximális terhelhetőséget/teljesítményt. Különben a bútor és annak alkatrészei megsérülhetnek, tönk्रे mehetnek.
<b>RO</b>	Nu depășiți solicitările maxime specificate. Altfel puteți să deteriorați sau să distrugeți piesa de mobilier.
<b>TR</b>	Belirtilen azami yük değerini aşmay n z, aksi takdirde mobilya parças zarar görebilir veya kullan lamaz hele gelebilir.
<b>RU</b>	Не допускается превышение указанных максимальных нагрузок. В противном случае возможно повреждение или разрушение мебели.



<b>D</b>	Ziehen Sie alle Schrauben sowie tragende Verbindungsteile nach ca. 5 Wochen nach, um eine dauerhafte Standsicherheit zu gewährleisten.
<b>GB</b>	After approx. 5 weeks, tighten all screws and load-bearing connecting parts to ensure permanent stability.
<b>FR</b>	Resserrez toutes les vis ainsi que les pièces de fixation au bout d'environ 5 semaines pour garantir une sécurité de fixation durable.
<b>IT</b>	Ristringere tutte le viti e giunture dopo ca. 5 settimane, al fine di garantire una durevole solidità.
<b>NL</b>	Draai alle schroeven en ook dragende verbindingstukken na ca. 5 weken nog eens vast, zodat een continue stabiliteit wordt gegarandeerd.
<b>PL</b>	Prosimy po ok. 5 tygodniach dokręcić wszystkie śruby w elementach łączeniowych. Zagwarantuje to Państwu trwałość i stabilność połączeń.
<b>CZ</b>	Dotáhněte všechny šrouby a nosné spojovací díly přibližně po 5 týdnech, aby se zaručila trvalá stabilita.
<b>SK</b>	Po cca 4 týždňoch dotiahnite skrutky, aby bola zaručená ich trvalá stabilita.
<b>HU</b>	Húzza utána – kb. 5 hét múlva – az összes csavart és a teherhordó összekötő-alkatrészeket a biztonság érdekében.
<b>RO</b>	Pentru a asigura o stabilitate de durată, strângeți după cca. 5 săptămâni toate șuruburile, precum și toate elementele portante de legătură.
<b>TR</b>	Tüm vida ve taş y c bağlant parçalar n kal c bir duruş güvenliğini sağlamak için yaklaşık 5 hafta sonra tekrar s k n z.
<b>RU</b>	Подкрутите все болты, а также несущие соединительные детали приibl. через 5 недель для обеспечения устойчивости в течение длительного времени.
<b>D</b>	Bitte nur mit einem Staubtuch oder leicht feuchtem Lappen reinigen. Keine scheuernden Putzmittel verwenden.
<b>GB</b>	Please only clean with a duster or a damp cloth. Do no use any abrasive cleaners.
<b>FR</b>	Veillez nettoyer uniquement avec un chiffon à poussière ou un chiffon légèrement humide. Ne pas utiliser de détergent abrasif.
<b>IT</b>	Si raccomanda di pulire sono con un panno per la polvere o uno strofinaccio umido. Non utilizzare detergenti abrasivi.
<b>NL</b>	Reinig alleen met een stofdoek of een lichtjes vochtige doek. Gebruik geen schurende poetsmiddelen.
<b>PL</b>	Czyszczenie należy wykonać wyłącznie za pomocą ściereczki lub lekko nawilżonego ręcznika. Nie stosować środków czyszczących do szorowania.
<b>CZ</b>	Čistěte prosím jen prachovkou nebo lehce navlhčeným hadrem. Nepoužívejte drhnoucí čisticí prostředky.
<b>SK</b>	Na čistenie používajte len prachovku alebo zľahka navlhčenú utierku. Nepoužívajte žiadne drhúce čistiace prostriedky.
<b>HU</b>	Kérjük, csak portórlő kendővel vagy enyhén nedves ronggyal tisztítsa. Ne használgjon dörzshatású tisztítószert.
<b>RO</b>	Vă rugăm să utilizați la curățare exclusiv o cârpă de șters praful sau o cârpă ușor umezită. Nu utilizați substanțe de curățat abrazive.
<b>TR</b>	Lütfen sadece bir toz beziyle veya hafif nemli yumuşak bir bezle siliniz. Aşındırıcı temizlik malzemeleri kullanmay n z.
<b>RU</b>	Очищайте от пыли тряпкой или слегка влажной ветошью. Не допускается применение чистящих средств, не предназначенных для ухода за мебелью.



**Dorel Home Europe Ltd**  
**Alphason House, 244 Swan Lane**  
**Hindley Green, Wigan WN2 4EY UK**  
**cseurope@dorel.com 01942 524100**