

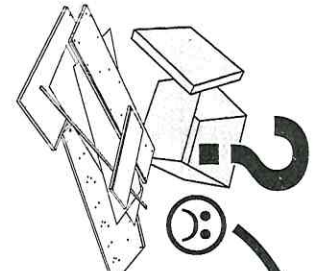

Service • Assistenza • Dienstverlening • Servis  
 Servis • Szerviz • Сервисная служба

AW3609

Name • Nom • Nome • Naam • Nazwa • Jméno • Nazov • Nev • Denimite • Ism • Haavanie	Jersey
Nr. • No. • N° • Номер • Č. Sz	
Typ • Type • Tip • Тип • Tipo • Тип	
	
	
	

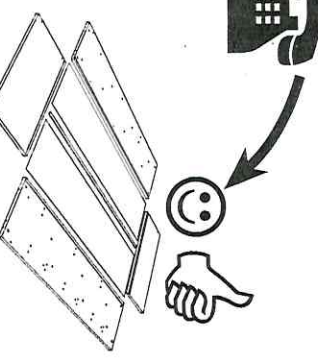
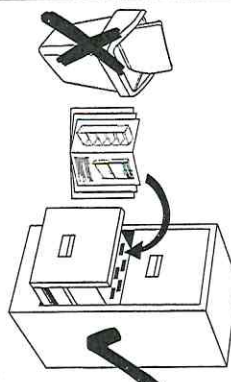
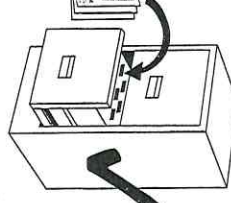
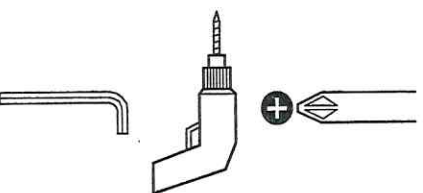
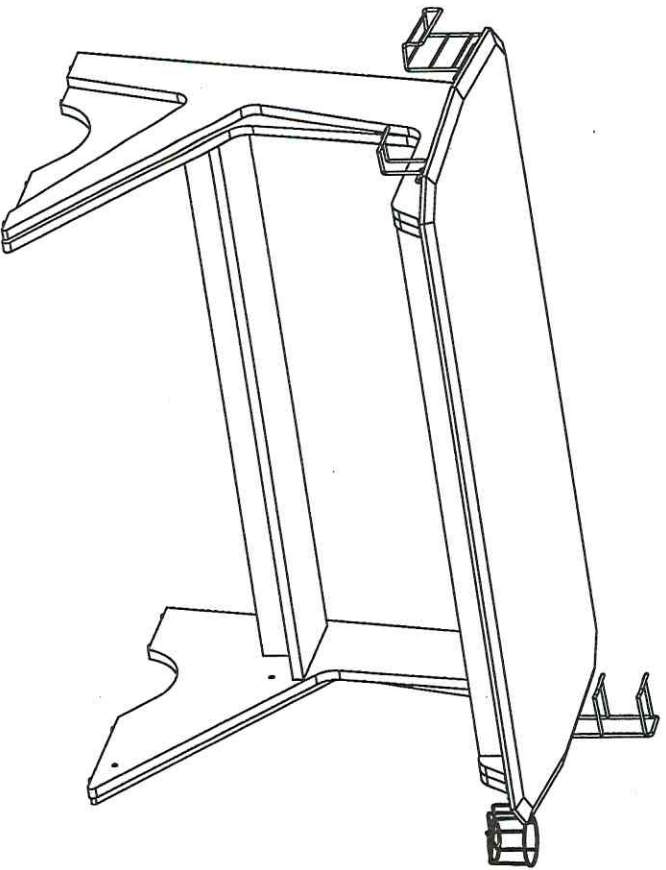

- D** Montageanleitung
- FR** Notice de montage
- NL** Handleiding voor de montage
- CZ** Montážní návod
- HU** Szerelési útmutató
- TR** Montaj talimatı
- GB** Assembly instructions
- IT** Istruzioni di montaggio
- PL** Instrukcja montażu
- SK** Návod na montáž
- RO** Instrucțiuni de montaj
- RU** Инструкция по монтажу

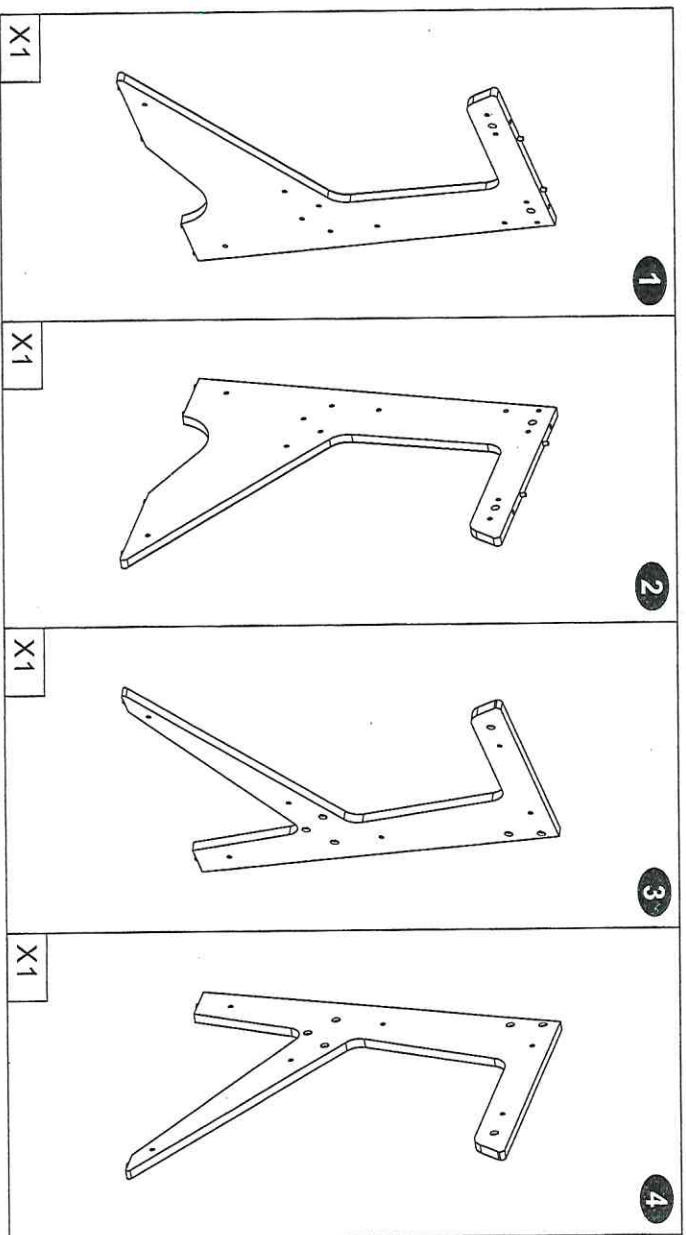
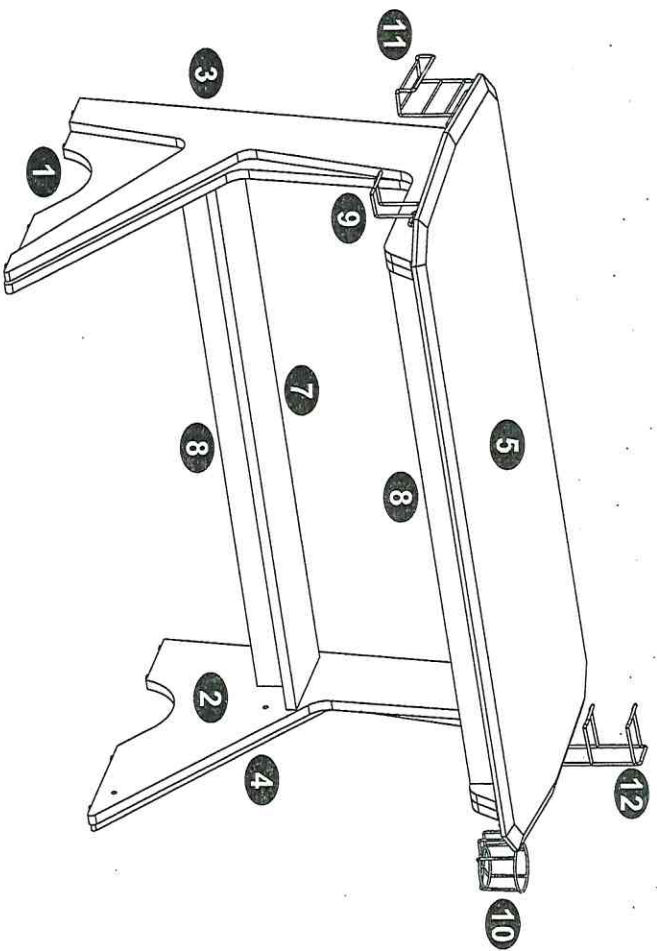

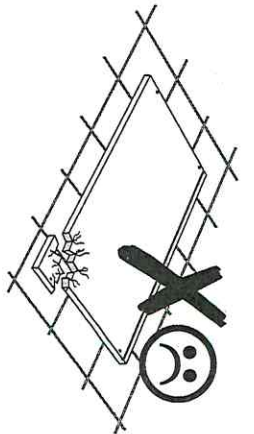
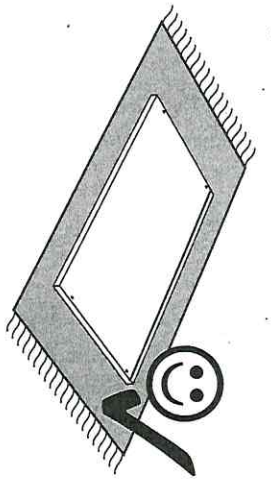
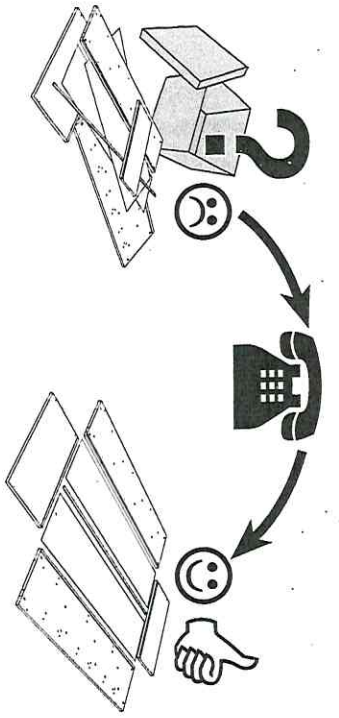

1

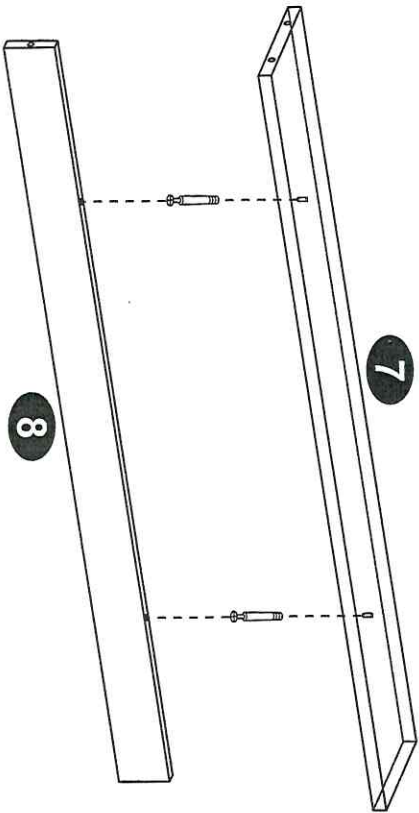
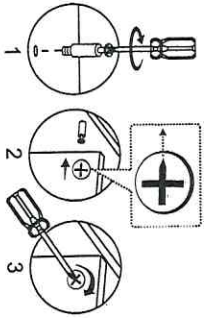
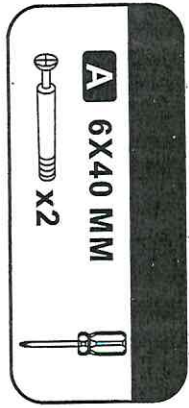

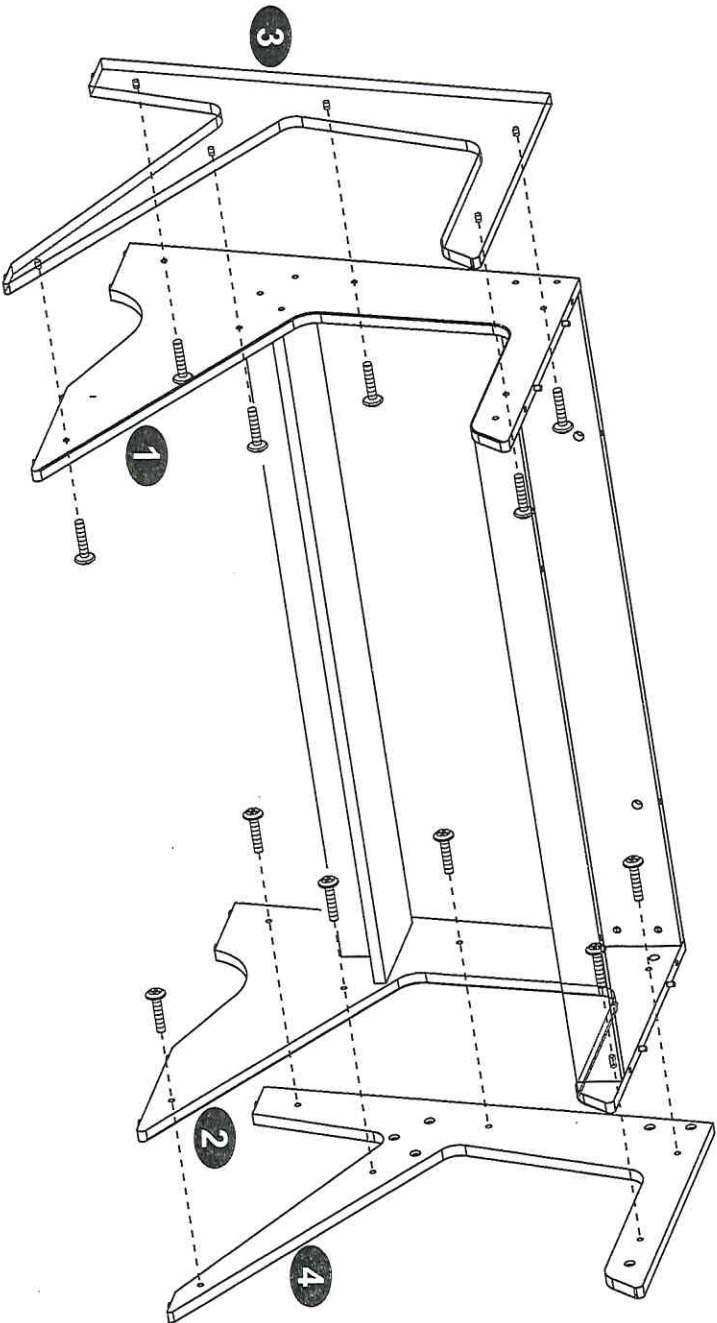

3

**B** 6X30 MM  
x12

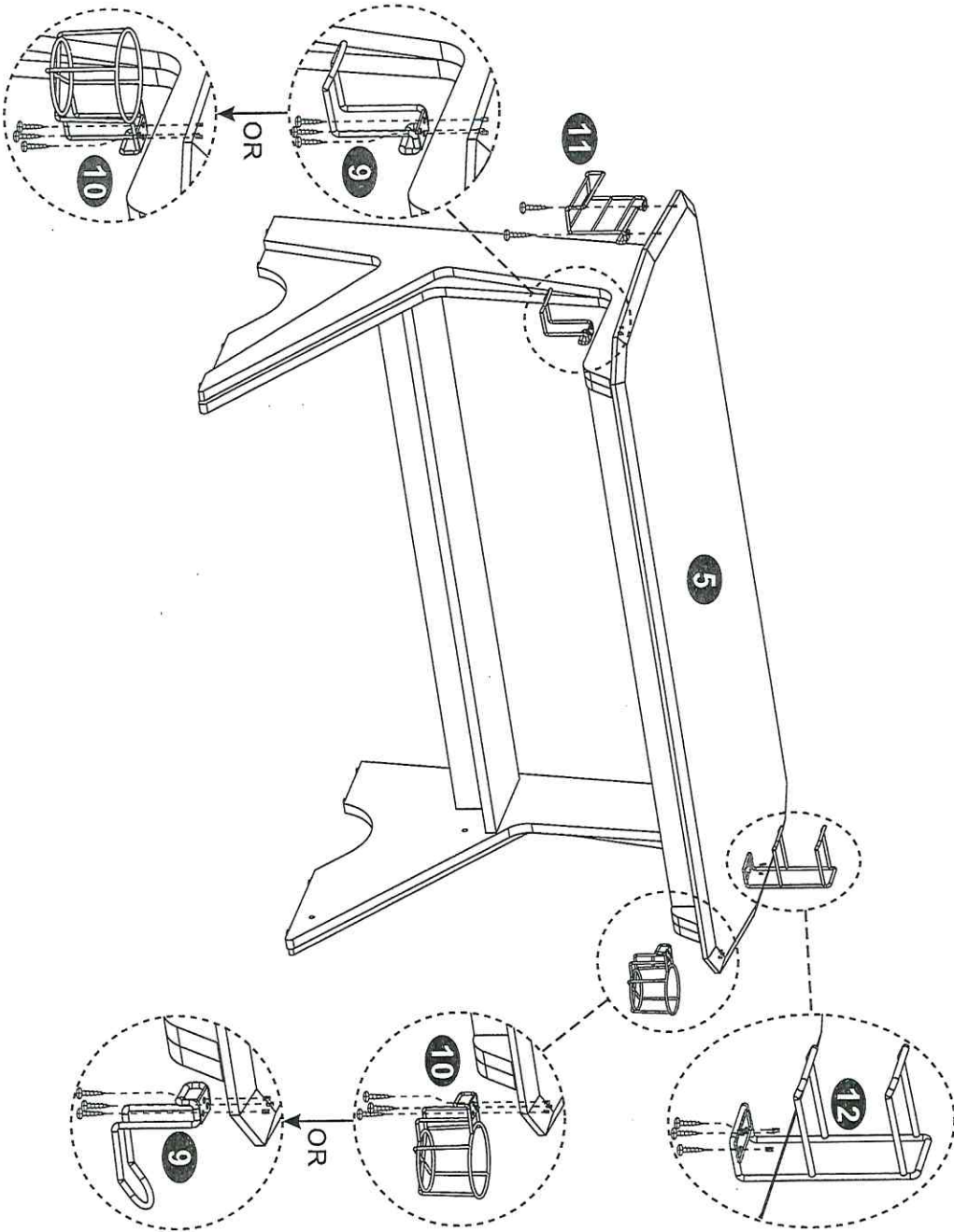

**D** 4X14 MM  
x11



7

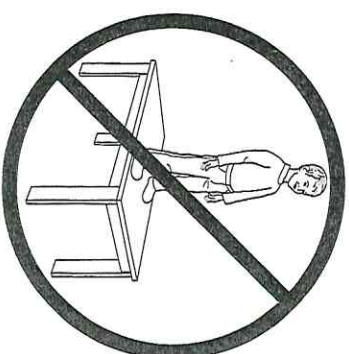
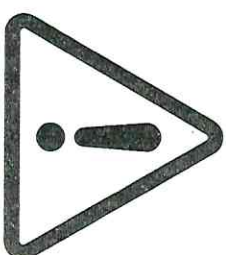
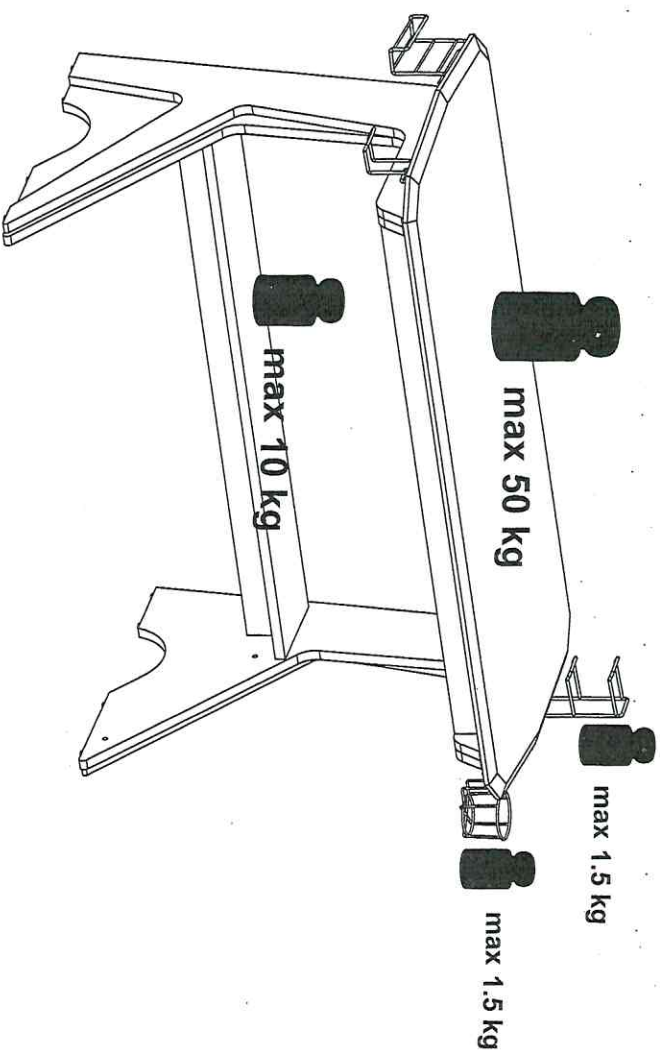

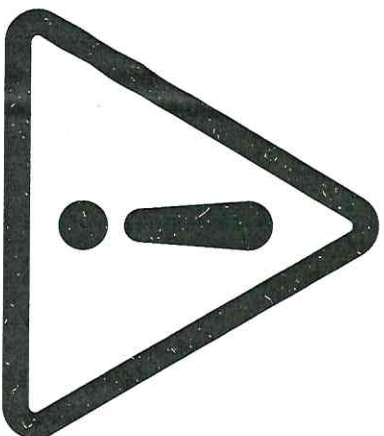

<b>D</b>	Überschreiten Sie die angegebenen Maximalbelastungen nicht. Andernfalls kann das Möbelstück beschädigt oder zerstört werden.
<b>GB</b>	Do not exceed the maximum loads specified. Otherwise, the furniture may sustain damage or be irreparably damaged.
<b>FR</b>	Ne dépassez pas les charges maximum indiquées. Sinon, le meuble peut être endommagé ou détruit.
<b>IT</b>	Non superare il carico massimo indicato. Altrimenti il mobile rischia di rovinarsi o frantumarsi.
<b>NL</b>	Overschrijd de aangegeven maximale belastingen niet. Anders kan het meubelstuk worden beschadigd of vernield.
<b>PL</b>	Nie wolno przekraczać podanych maksymalnych wartości obciążenia. W przeciwnym razie mebel może zostać uszkodzony lub zniszczony.
<b>CZ</b>	Nepřekračujte uvedená maximální zatížení. V opačném případě může dojít k poškození nebo zničení nábytku.
<b>SK</b>	Neprekročte uvedené maximálne zaťaženia. V opačnom prípade sa môže nábytok poškodiť alebo zničiť.
<b>HU</b>	Tartsa be az engedélyezett maximális terhelhetőséget/terheléstmenyt. Különben a bútor és annak alkatrészei megsérülhetnek, tönkbe mehetnek.
<b>RO</b>	Nu depășiți solicitările maxime specificate. Altfel puteți să deteriorați sau să distrugeți piesa de mobilier.
<b>TR</b>	Belirtilen aza mi yük deęerini ařmayınız, aksi takdirde mobilya parçası zarar görebilir veya kullanılamaz hale gelebilir.
<b>RU</b>	Не допускаются превышение указанных максимальных нагрузок. В противном случае возможно повреждение или разрушение мебели.

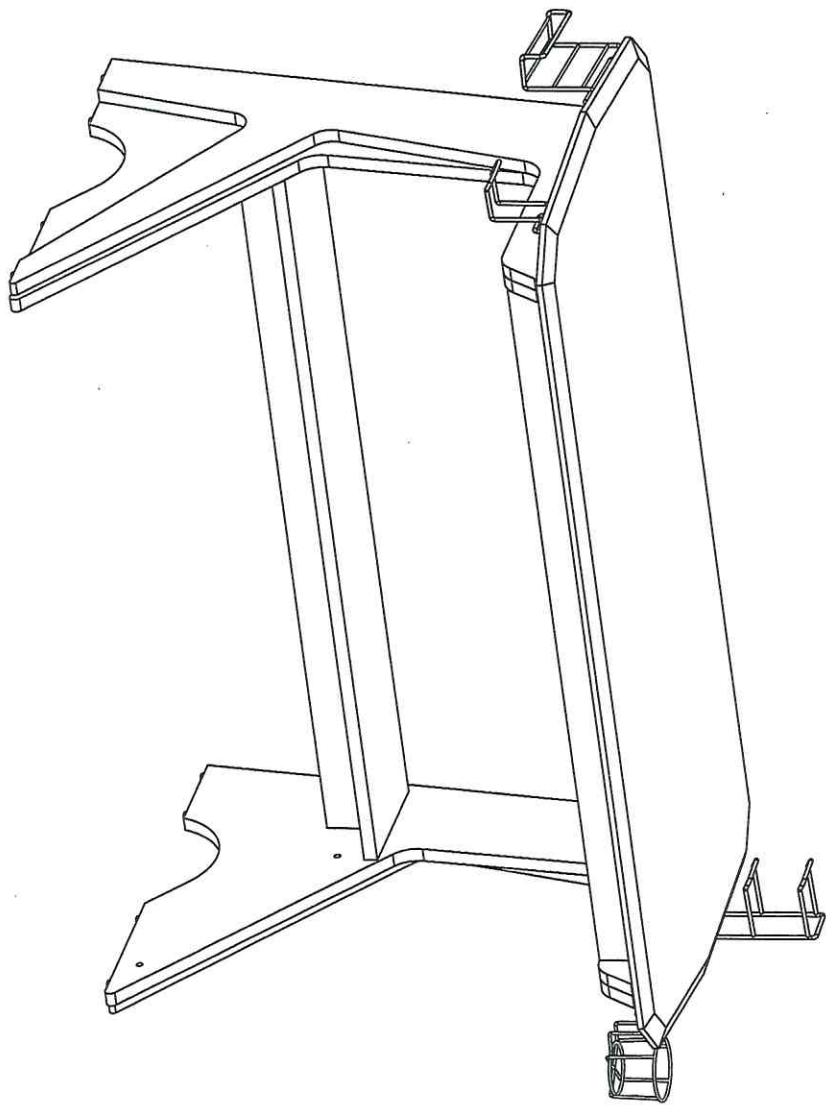

<b>D</b>	Ziehen Sie alle Schrauben sowie tragende Verbindungsstelle nach ca. 5 Wochen nach, um eine dauerhafte Standsicherheit zu gewährleisten.
<b>GB</b>	After approx. 5 weeks, tighten all screws and load-bearing connecting parts to ensure permanent stability.
<b>FR</b>	Resserrez toutes les vis ainsi que les pièces de fixation au bout d'environ 5 semaines pour garantir une sécurité de fixation durable.
<b>IT</b>	Ristringere tutte le viti e giunture dopo ca. 5 settimane, al fine di garantire una durevole solidità.
<b>NL</b>	Draai alle schroeven en ook dragende verbindingstukken na ca. 5 weken nog eens vast, zodat een continue stabiliteit wordt gegarandeerd.
<b>PL</b>	Prosimy po ok. 5 tygodniach dokręcić wszystkie śruby w elementach łączeniowych. Zagwarantuje to Państwu trwałość i stabilność połączeń.
<b>CZ</b>	Dotáhněte všechny šrouby a nosné spojovací díly přibližně po 5 týdnech, aby se zaručila trvalá stabilita.
<b>SK</b>	Po cca 4 týždňoch dotiahnite skrutky, aby bola zaručená ich trvalá stabilita.
<b>HU</b>	Húzza utána – kb. 5 hét múlva – az összes csavart és a teherhordó összekötő-alkatrészeket a biztonság érdekében.
<b>RO</b>	Pentru a asigura o stabilitate de durată, strângeți după cca. 5 săptămâni toate șuruburile, precum și toate elementele portante de legătură.
<b>TR</b>	Tüm vida ve taşıyıcı bağlantı parçalarını kalıcı bir duruş güvenciliğini sağlamak için yaklaşık 5 hafta sonra tekrar sıkınız.
<b>RU</b>	Подкрутите все болты, а также несущие соединительные детали прибр. через 5 недель для обеспечения устойчивости в течение длительного времени.
<b>D</b>	Bitte nur mit einem Staubtuch oder leicht feuchtem Lappen reinigen. Keine scheuernden Putzmittel verwenden.
<b>GB</b>	Please only clean with a duster or a damp cloth. Do not use any abrasive cleaners.
<b>FR</b>	Veillez nettoyer uniquement avec un chiffon à poussière ou un chiffon légèrement humide. Ne pas utiliser de détergent abrasif.
<b>IT</b>	Si raccomanda di pulire solo con un panno per la polvere o uno strofinaccio umido. Non utilizzare detergenti abrasivi.
<b>NL</b>	Reinig alleen met een stofdoek of een lichtjes vochtige doek. Gebruik geen schurende poetsmiddelen.
<b>PL</b>	Czyszczenie należy wykonać wyłącznie za pomocą ściereczki lub lekko nawilżonego ręcznika. Nie stosować środków czyszczących do szorowania.
<b>CZ</b>	Čistěte prosím jen prachovkou nebo lehce navlhčeným hadrem. Nepoužívejte drhnutí čistící prostředky.
<b>SK</b>	Na čistenie používajte len prachovku alebo zľahka navlhčenú utierku. Nepoužívajte žiadne drhnutie čistiace prostriedky.
<b>HU</b>	Kéjük, csak portórtól kendővel vagy enyhén nedves ronggyal tisztítsa. Ne használjon dörzsható sú tisztítószert.
<b>RO</b>	Vă rugăm să utilizați la curățare exclusiv o cârpă de șters prafuri sau o cârpă ușor umezită. Nu utilizați substanțe de curățat abrazive.
<b>TR</b>	Lüften sadece bir toz bezyle veya hafif ıslanmış bir bezle siliniz. Aşındırıcı temizlik malzemeleri kullanmayınız.
<b>RU</b>	Очищайте от пыли тряпкой или слегка влажной ветошью. Не допускаются применение чистящих средств, не предназначенных для ухода за мебелью.



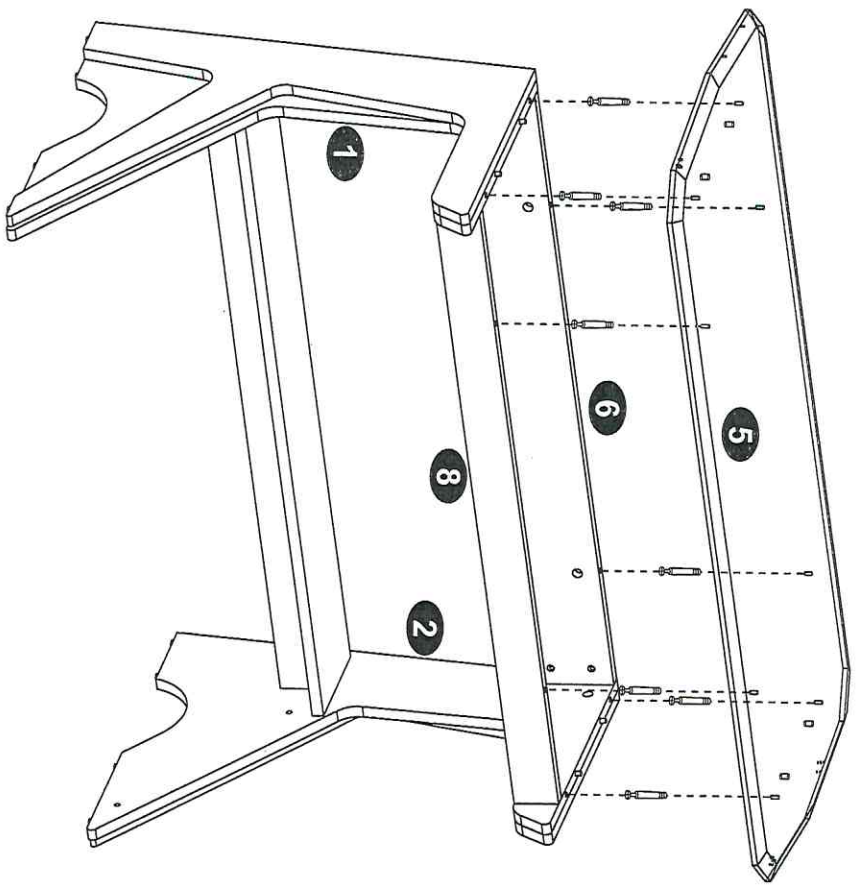
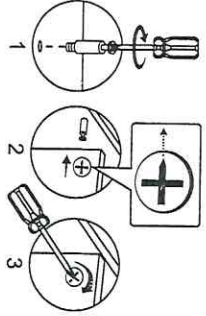



**A** 6X40 MM  
x8

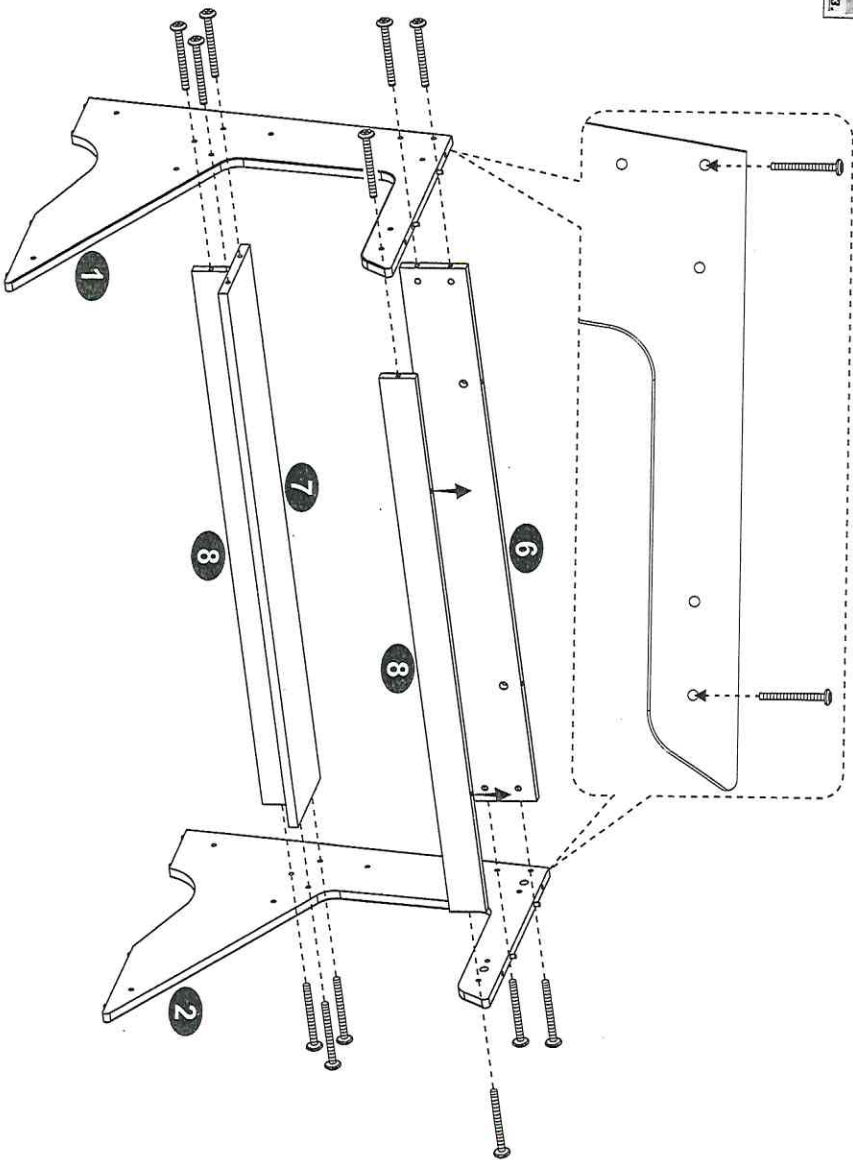
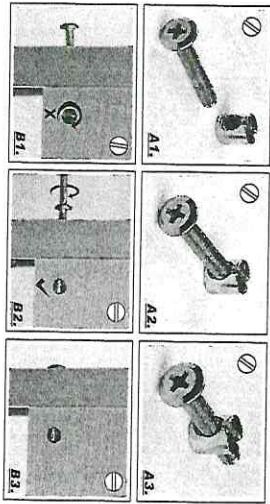

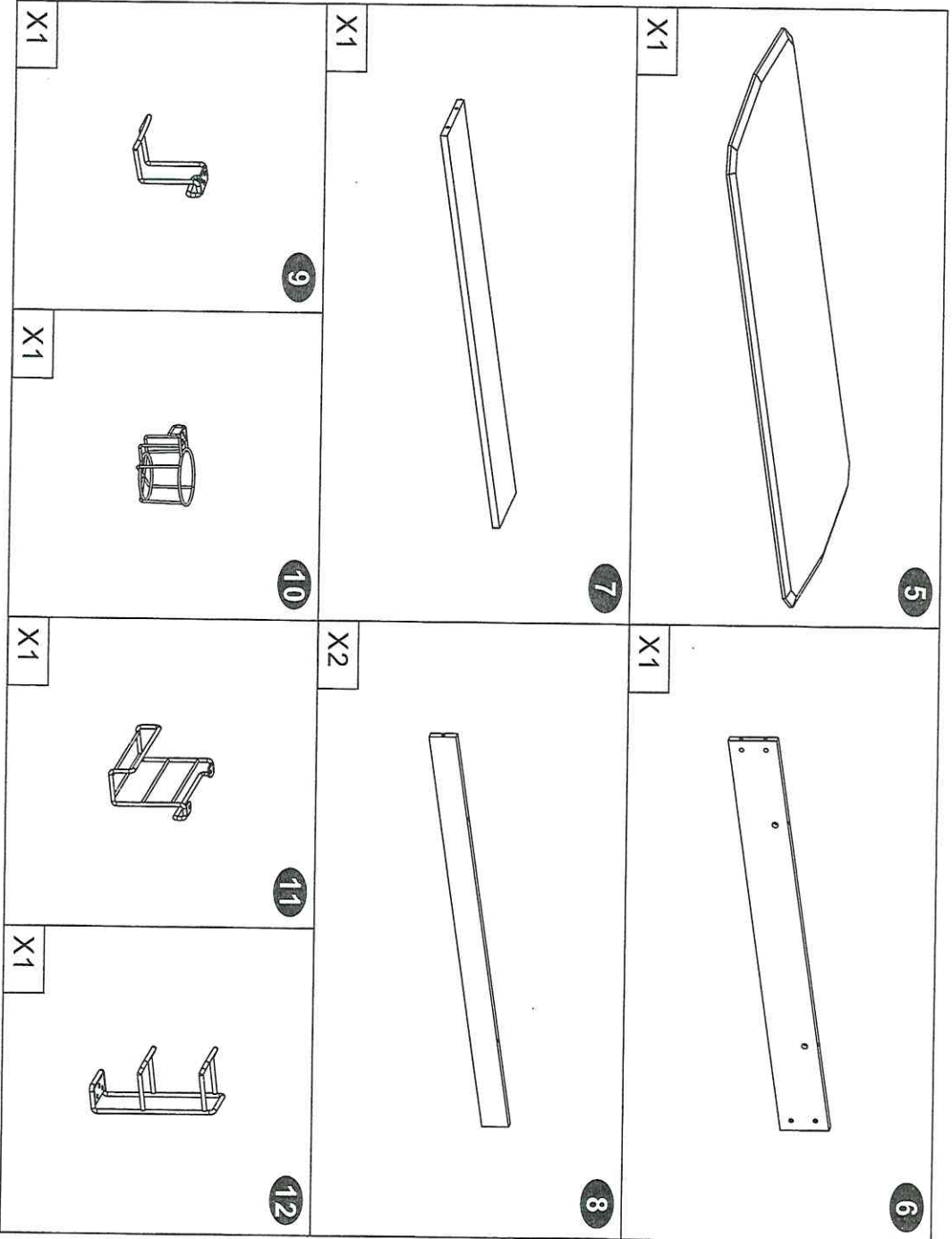
**C** 6X55 MM  
X12



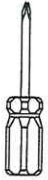

<b>A</b>	10	6X40 MM	
<b>B</b>	12	6X30 MM	
<b>C</b>	12	6X55 MM	

<b>D</b>	11	4X14 MM	
	1		

**6X40MM**

