

Service • Assistenza • Dienstverlening • Servis
 Servis • Szerviz • Сервисная служба

AW3622

Name • Nom • Nome • Naam • Nazwa • Jméno • Názov • Név • Denumire • İsim • Название	Palmer
Nr. • No. • N° • Номер • Č. • Sz Typ • Type • Tip • Tipus • Tipo • Тип	
	
	
	

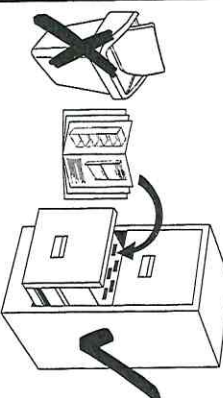
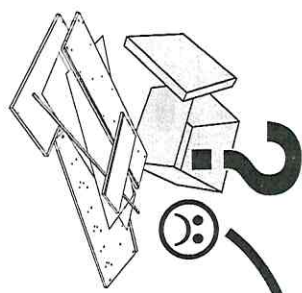
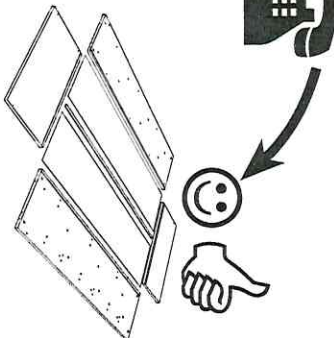
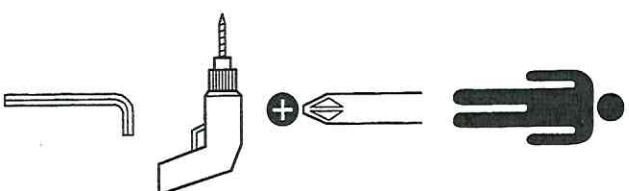
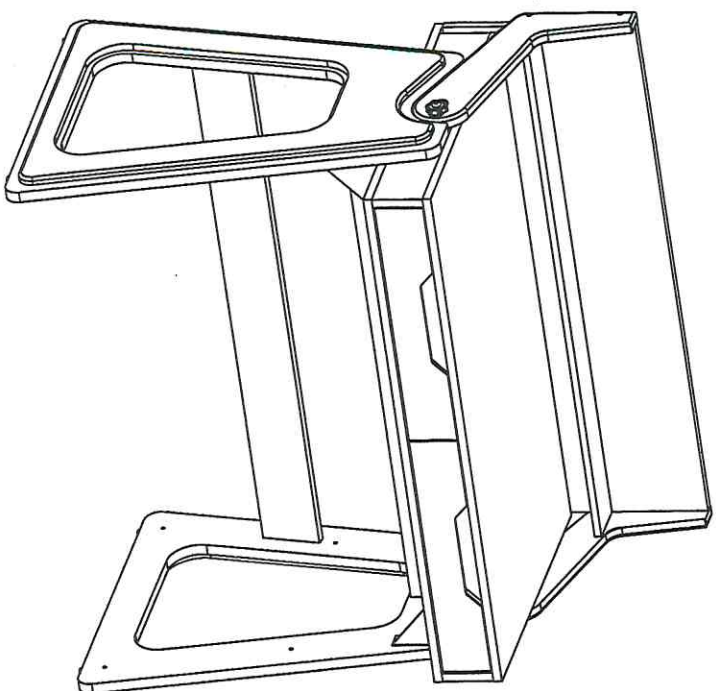

D Montageanleitung

FR Notice de montage

NL Handleiding voor de montage

CZ Montážní návod

HU Szerelési útmutató

TR Montaj talimatı

GB Assembly instructions

















IT Istruzioni di montaggio

PL Instrukcja montażu

SK Návod na montáž







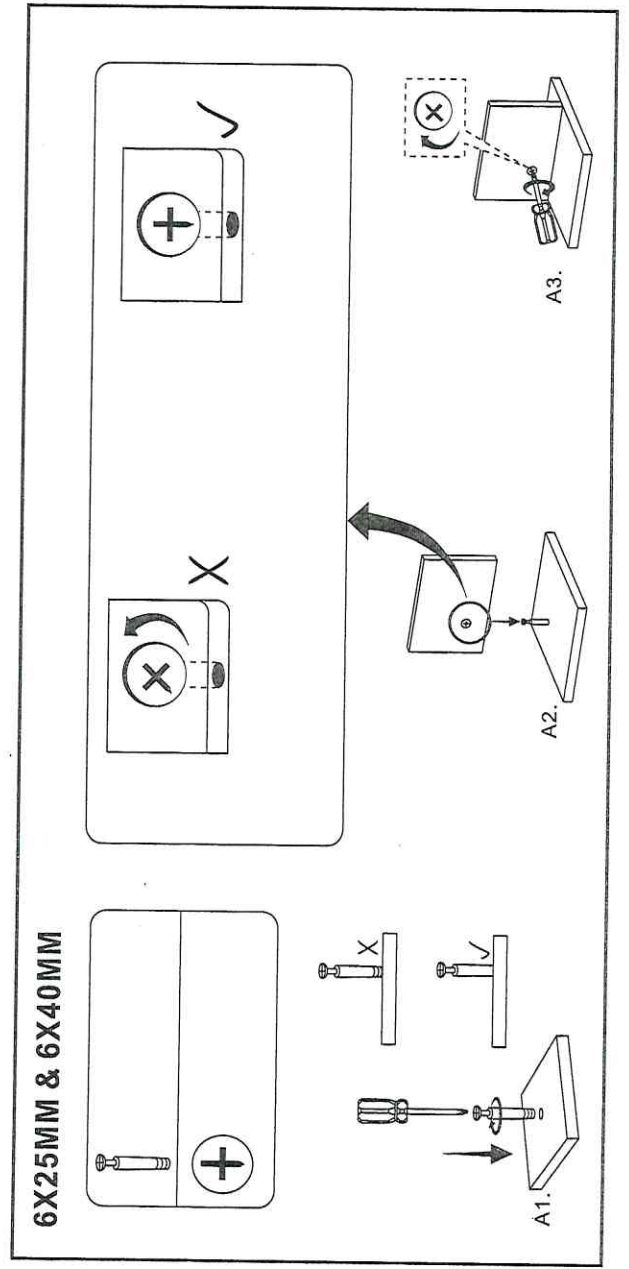

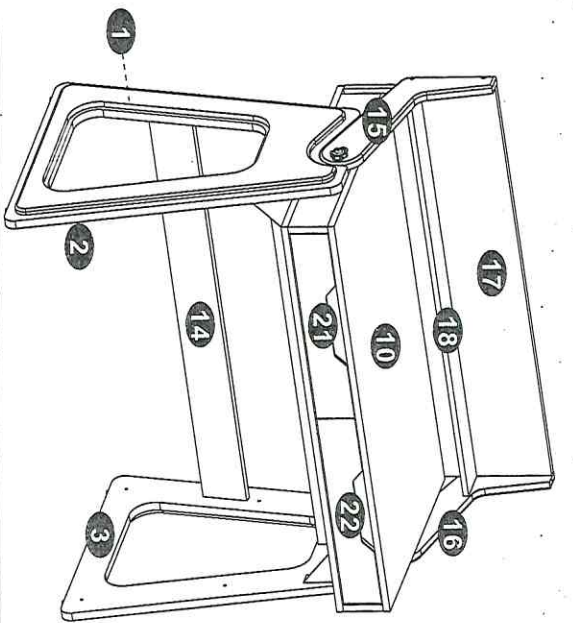
RO Instrucțiuni de montaj

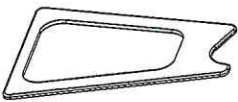
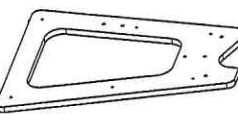
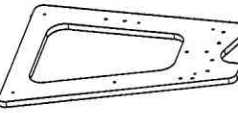
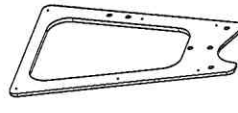
RU Инструкция по монтажу

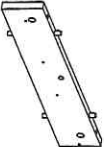
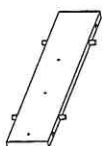
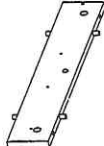
A	8	6X40 MM		J	8	4X35 MM	
B	12	6X12 MM		K	2	M 8	
C	12	6X55 MM		L	2	Φ 20MM	
D	2	8X45 MM		M	2	Φ 24MM	
E	12	5X40 MM		N	2	Φ 16MM	
F	8	6X25 MM			1	M 5	
G	16	3X12 MM			1		
H	12	3X15 MM			1		
I	12	4X28 MM					



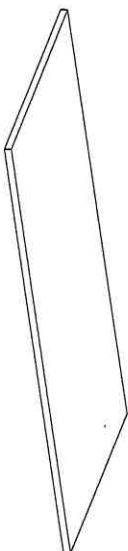

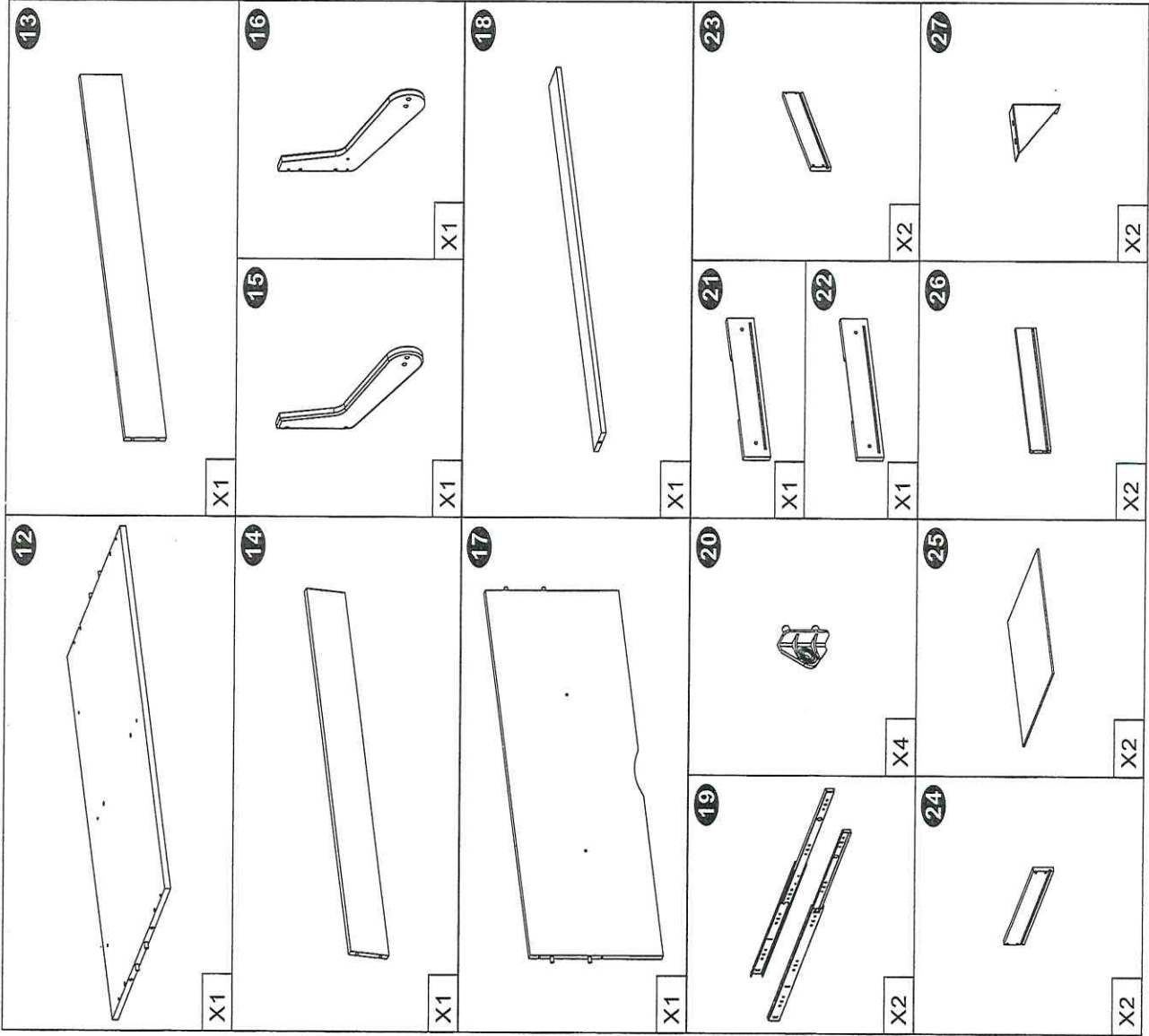

 <p>1</p>	 <p>2</p>	 <p>3</p>	 <p>4</p>
 <p>5</p>	 <p>7</p>	 <p>8</p>	 <p>9</p>
 <p>6</p>	 <p>10</p>	 <p>11</p>	
 <p>10</p>		 <p>11</p>	

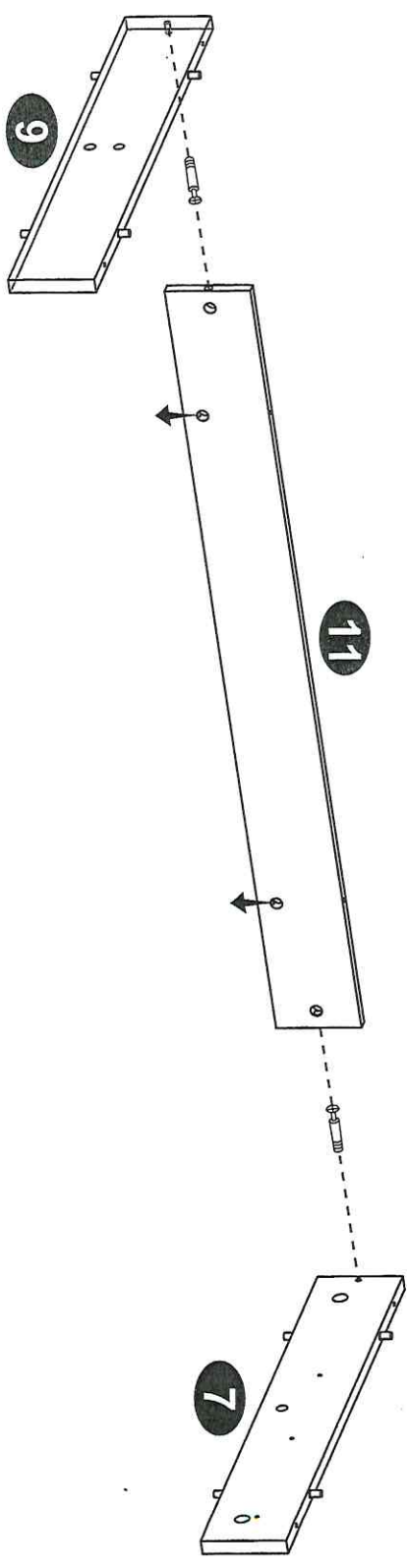
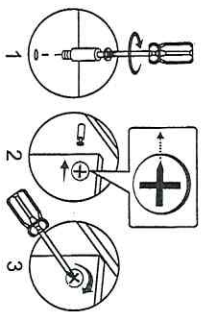
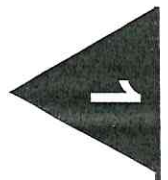
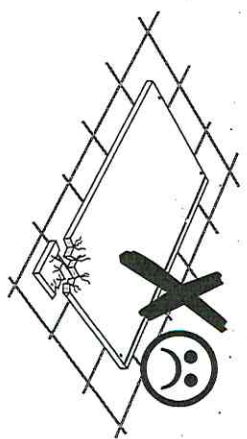
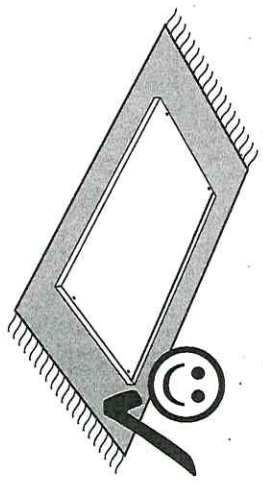
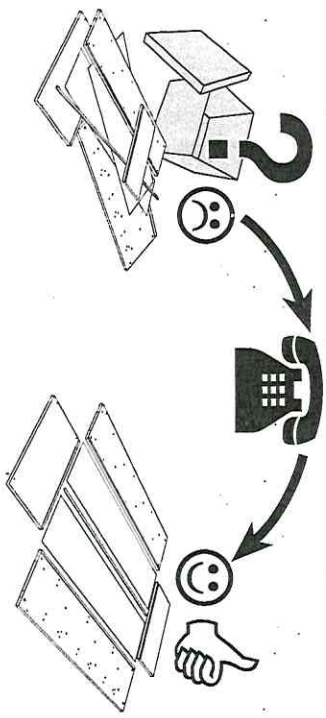





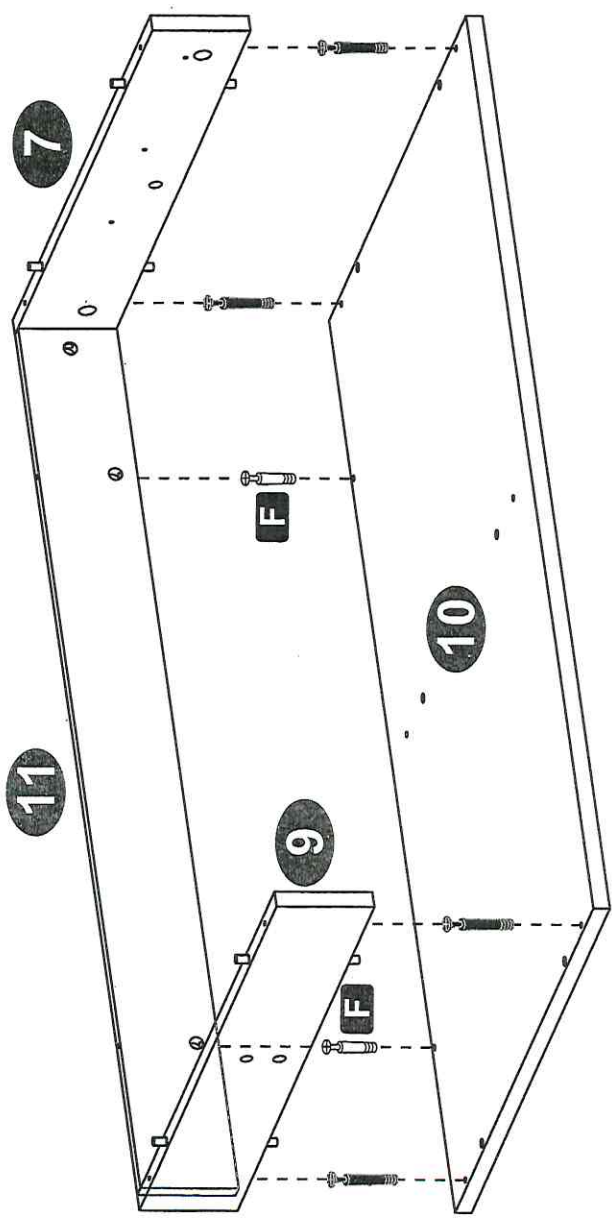
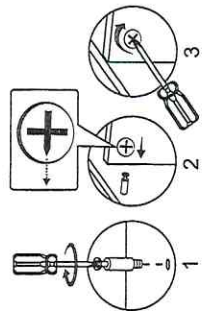

2

A 6X40 MM  x4	F 6X25 MM  x2
--	--

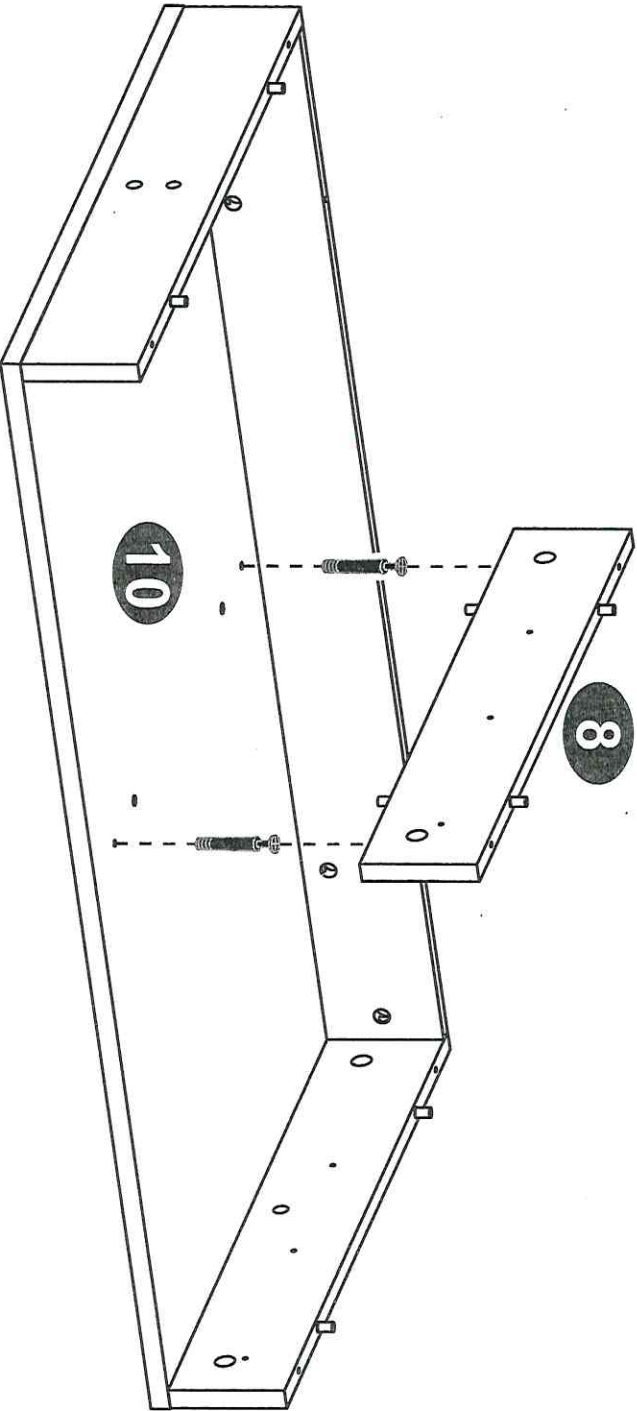
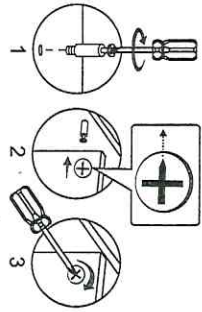



A 6X40 MM
x2

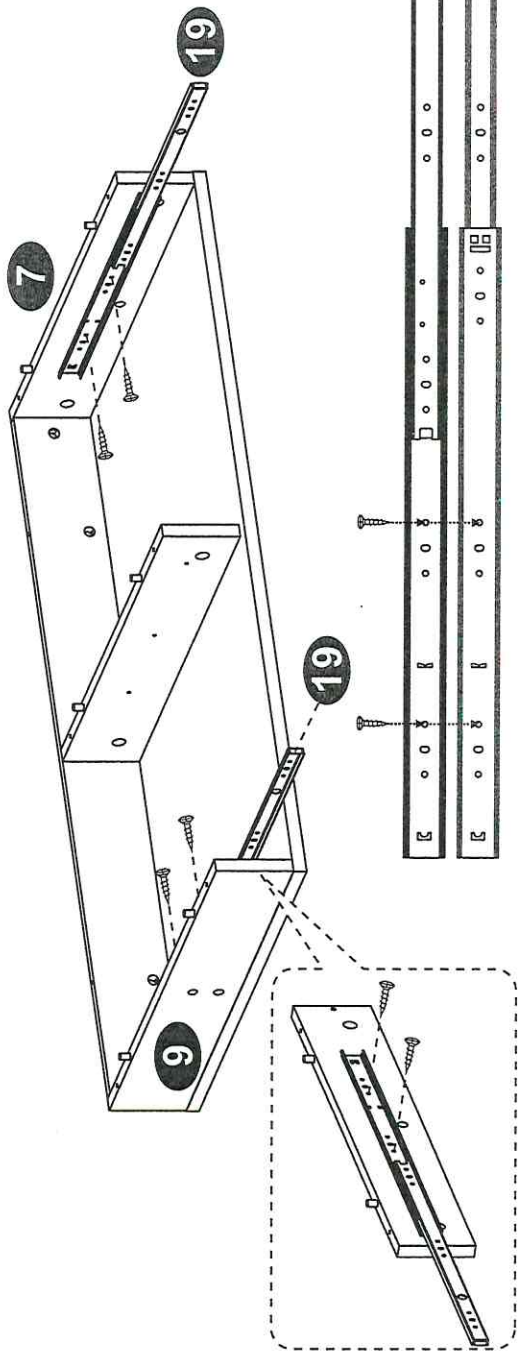
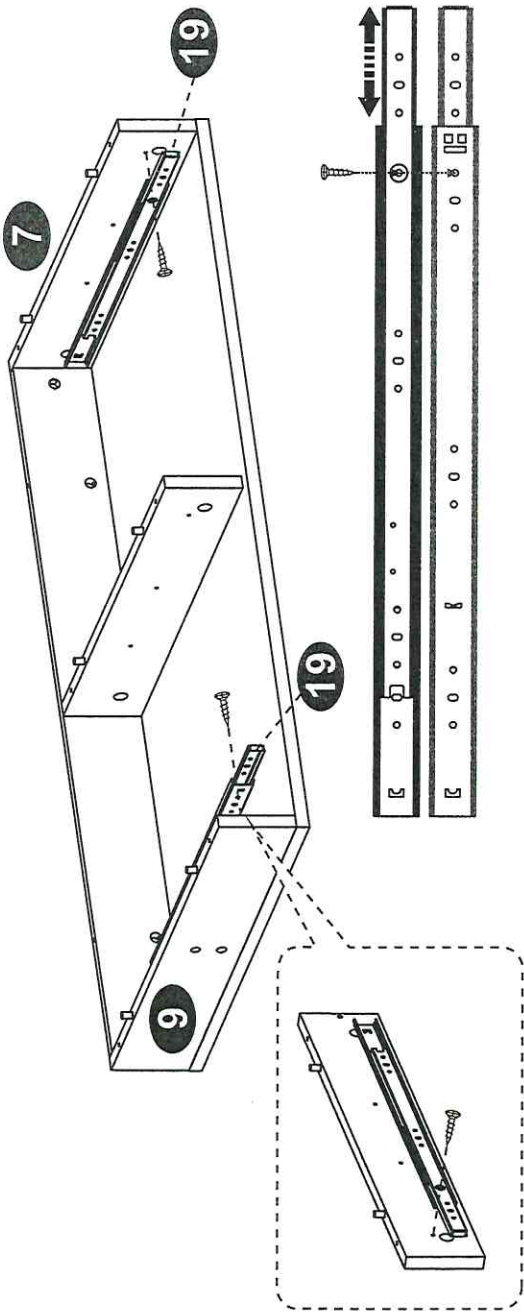

H 3X15 MM
x6

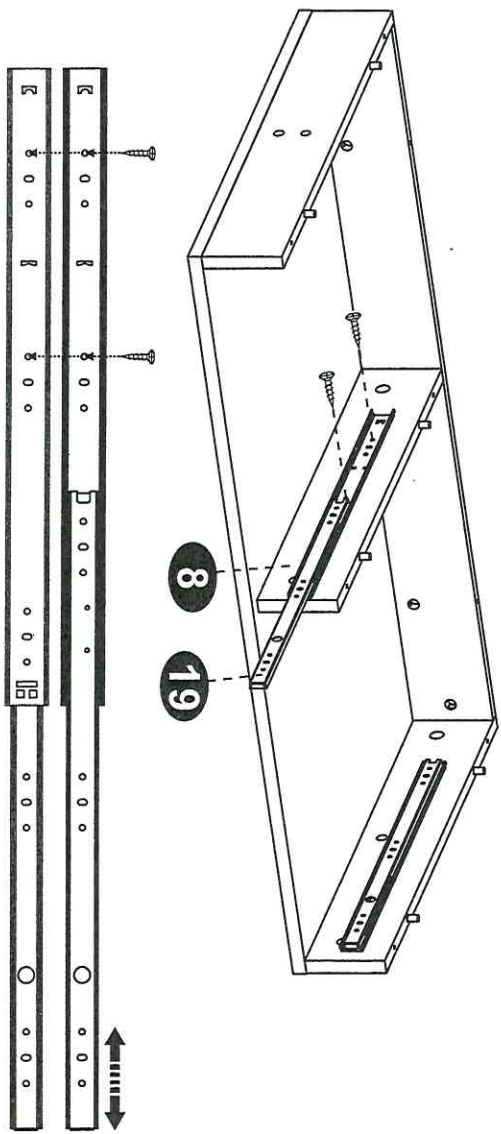
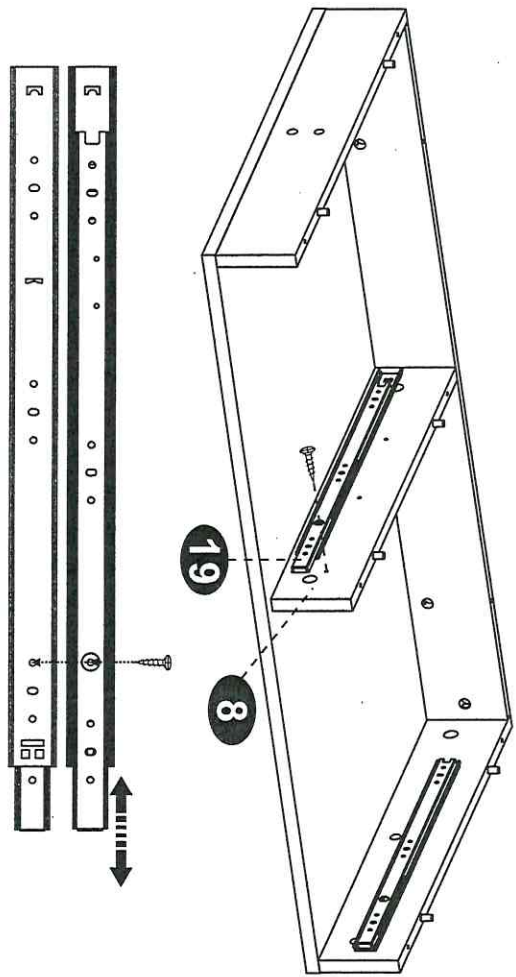

H 3X15 MM
x3



6

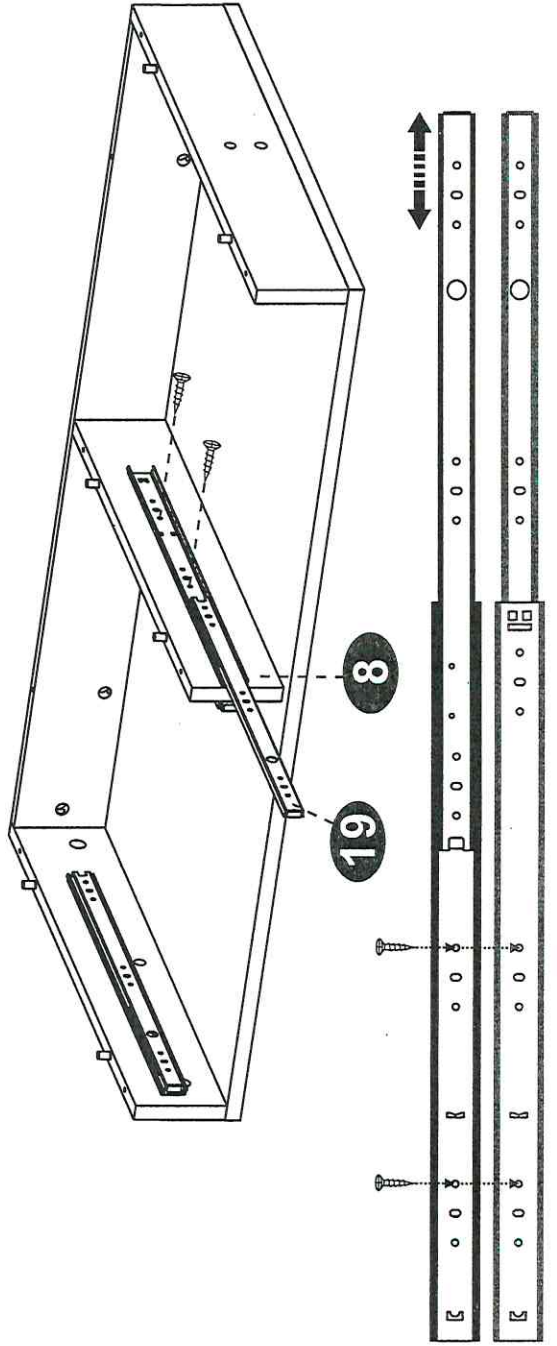
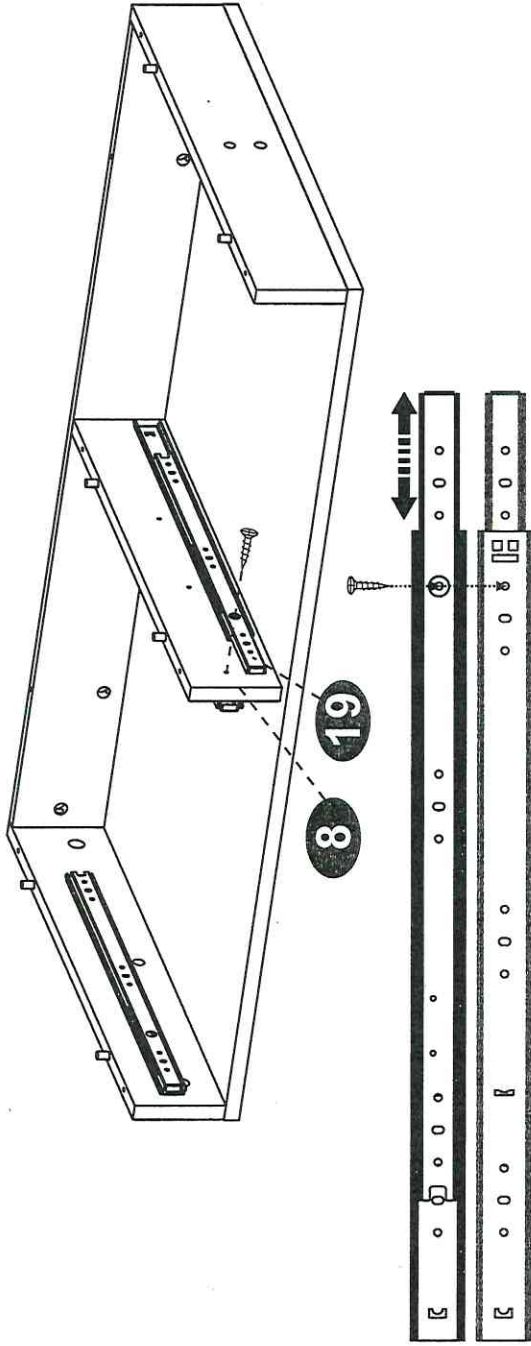

E 5X40 MM
x8

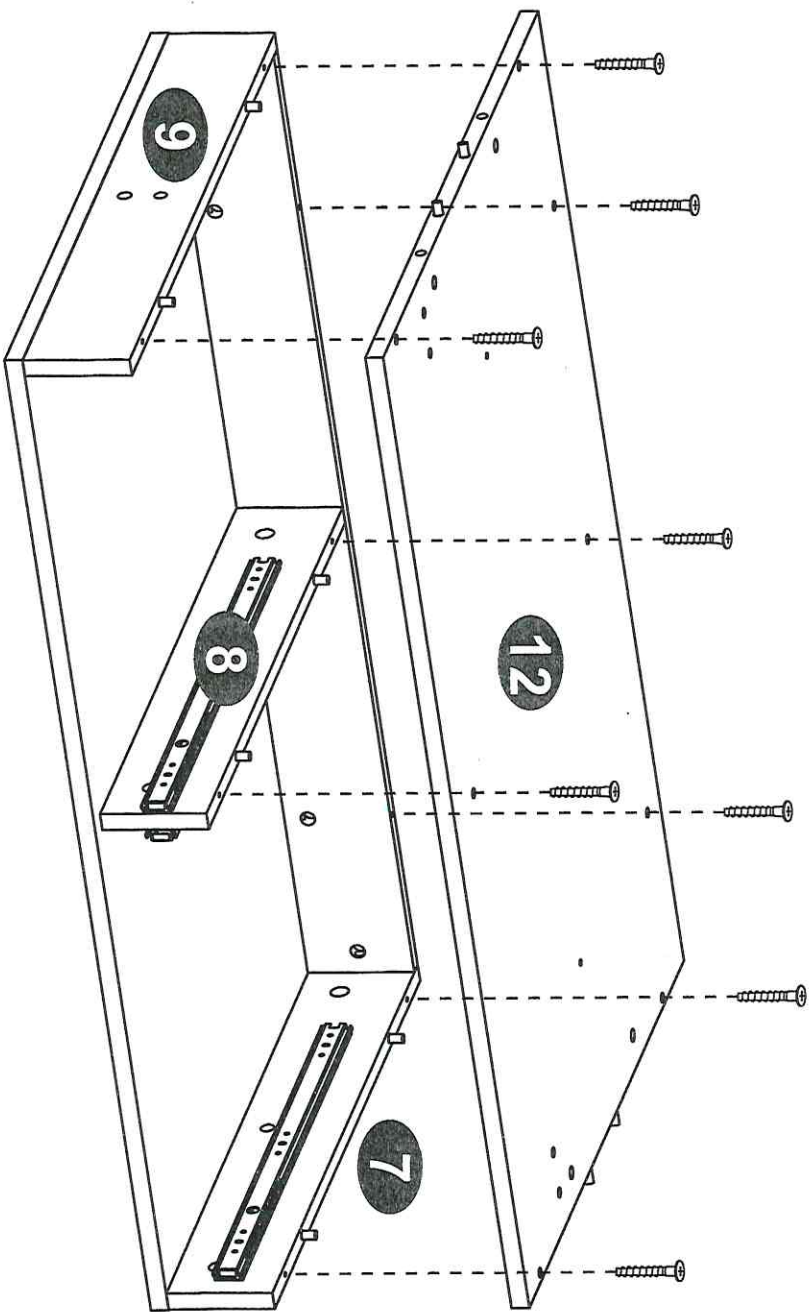
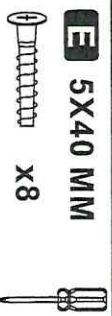

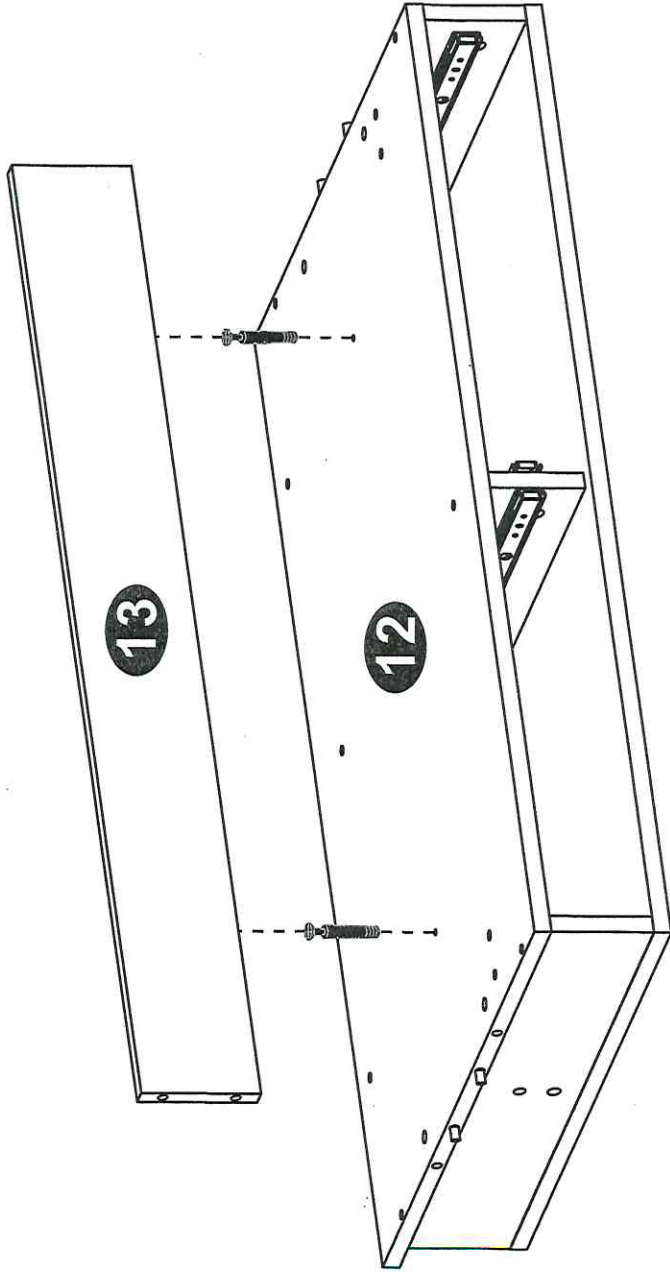
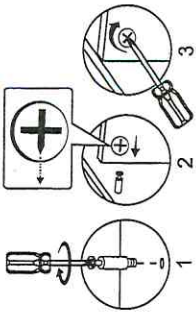



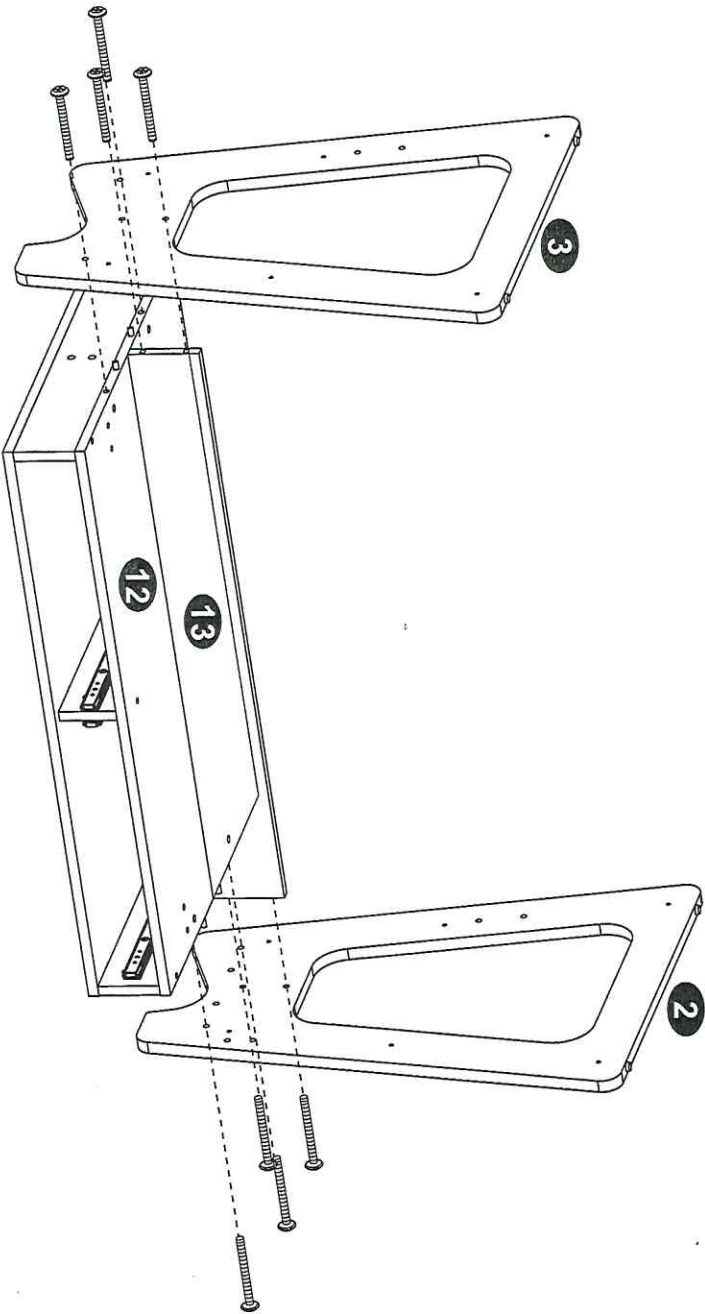
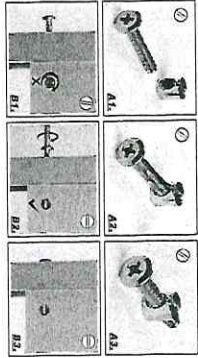



 **C** 6X55 MM
 X8



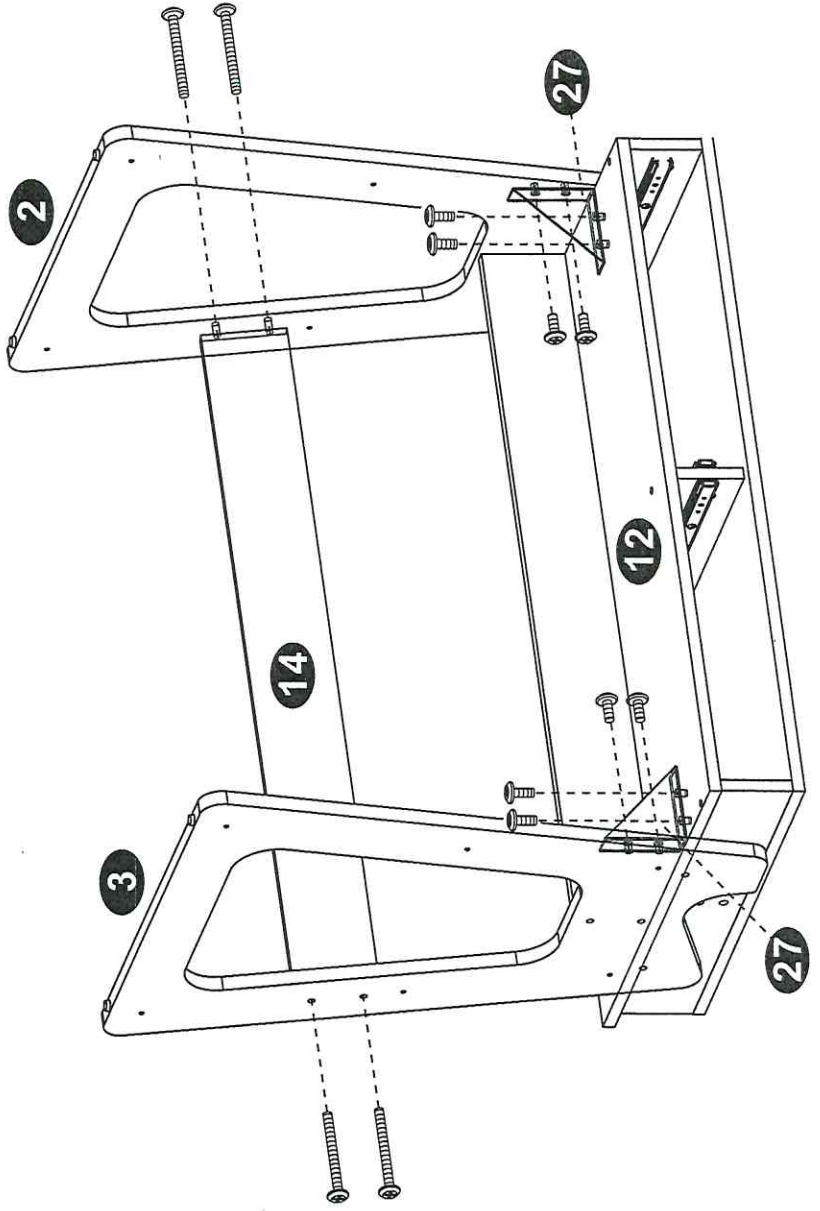
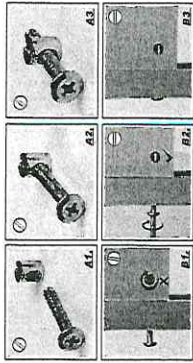

10

B	6X12 MM	
	x8	
C	6X55 MM	
	x4	

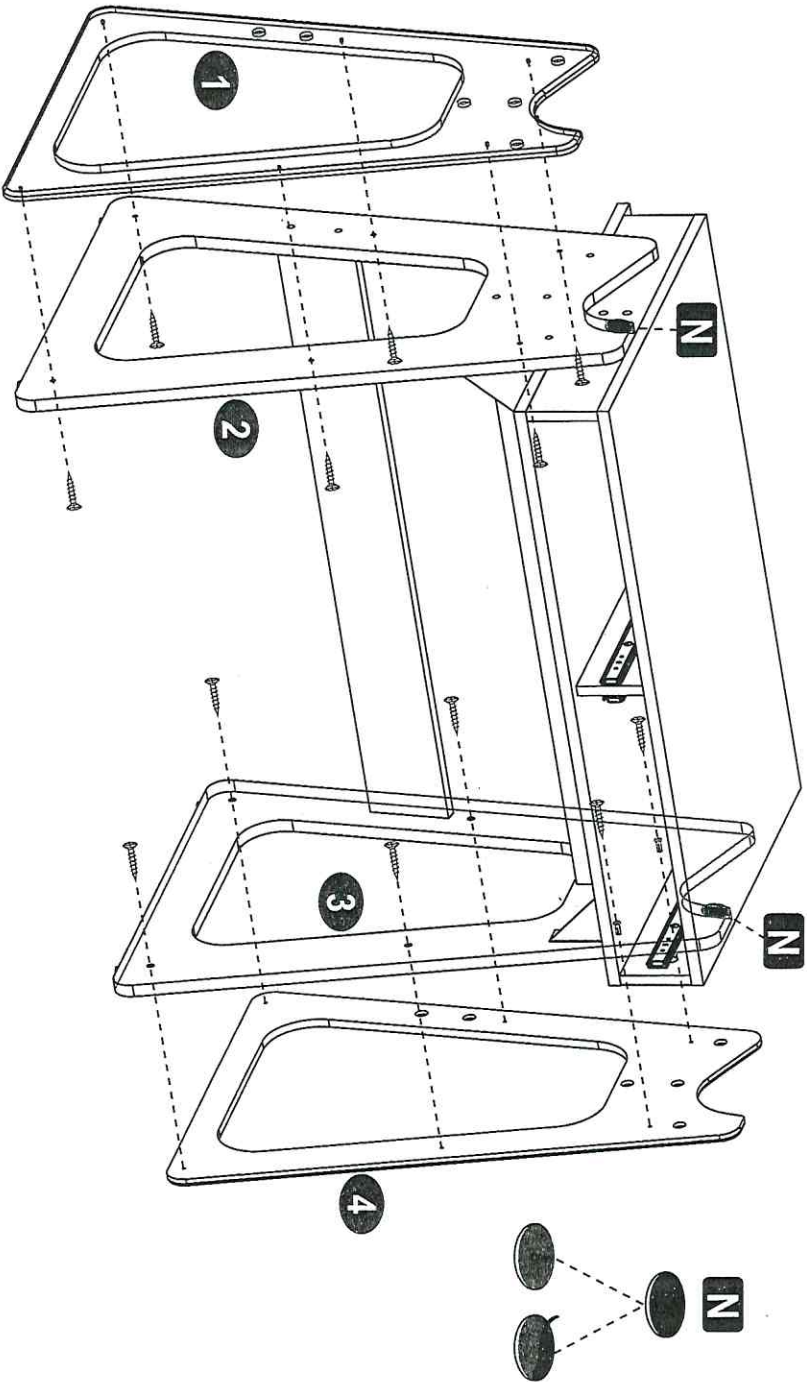

 $\Phi 16\text{MM}$ x2	 4X28 MM x12
--	--





12

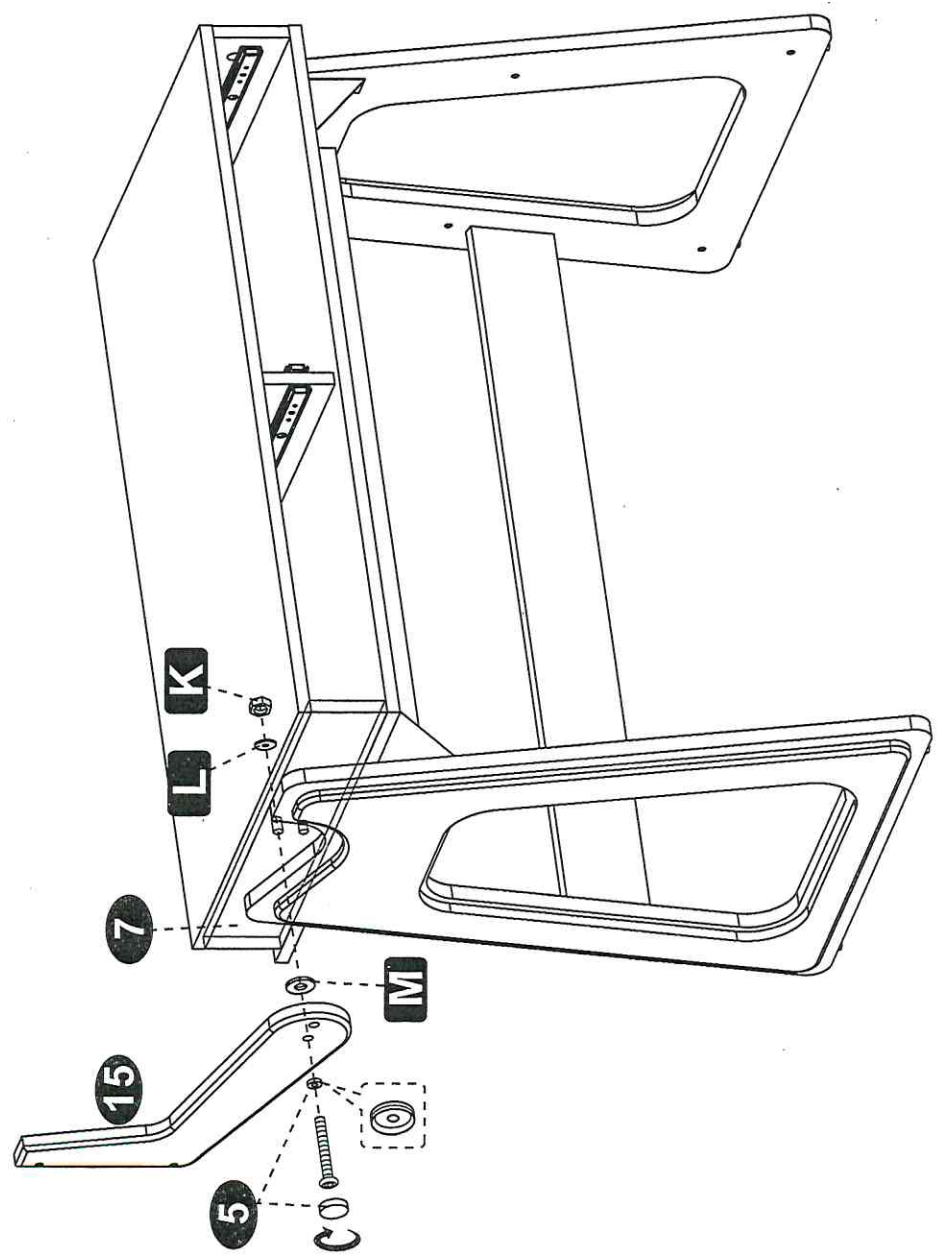



L Φ 20MM x1	D 8X45 MM x1
M Φ 24MM x1	K M 8 x1

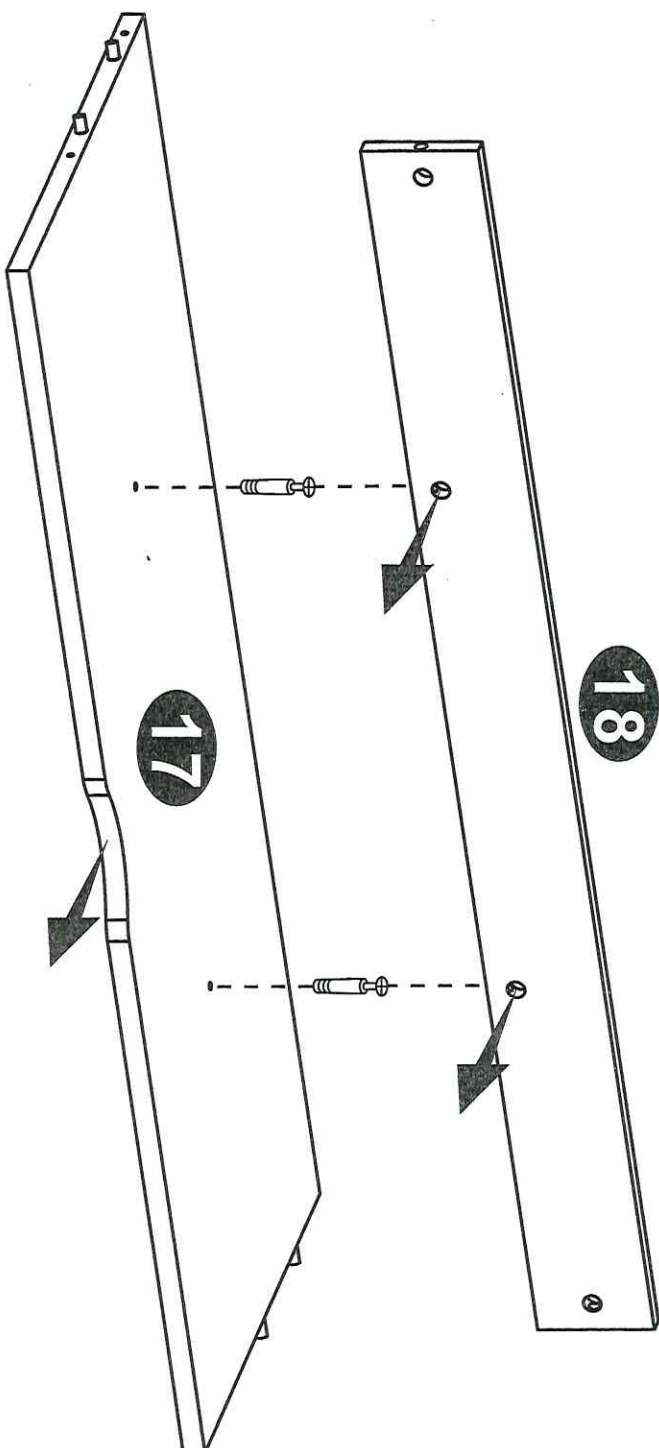
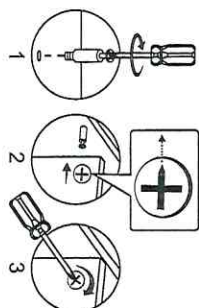







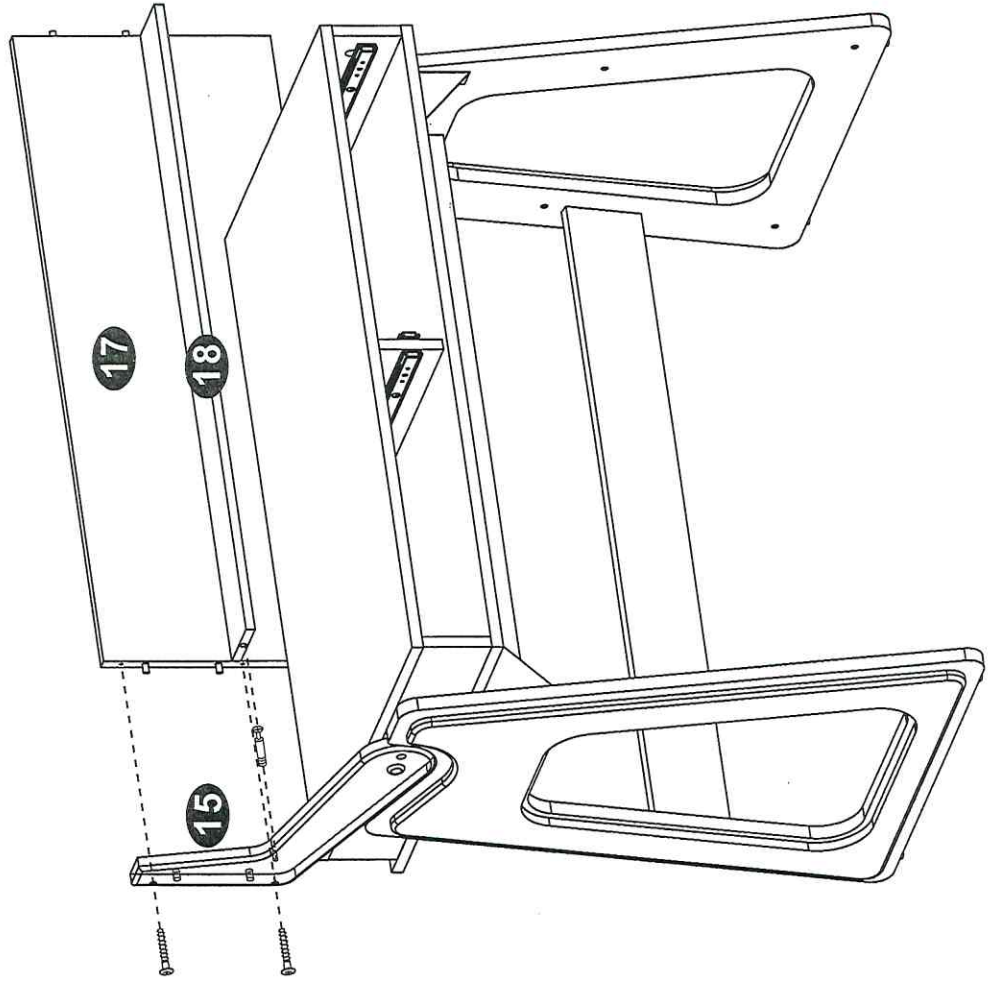
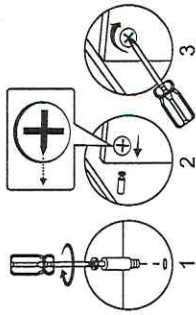

13

F 6X25 MM
x2



E 5X40 MM	
	x2
F 6X25 MM	
	x1



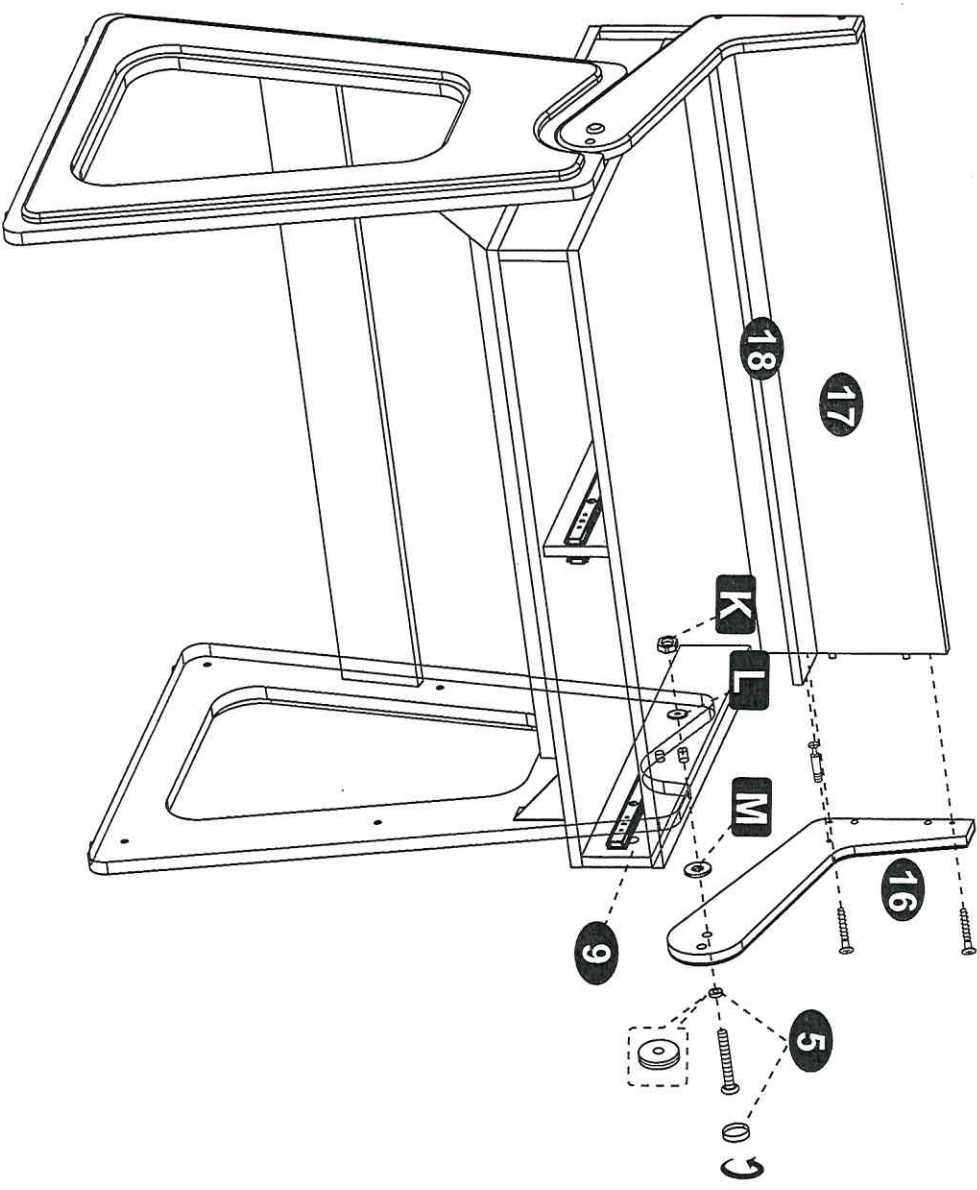
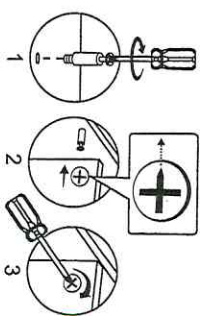

L Φ 20MM  x1	D 8X45 MM  x1	E 5X40 MM  x2
M Φ 24MM  x1	K M 8  x1	F 6X25 MM  x1
		



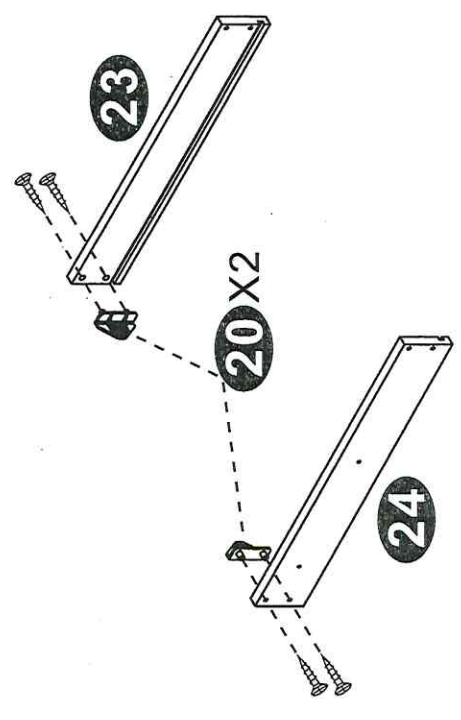
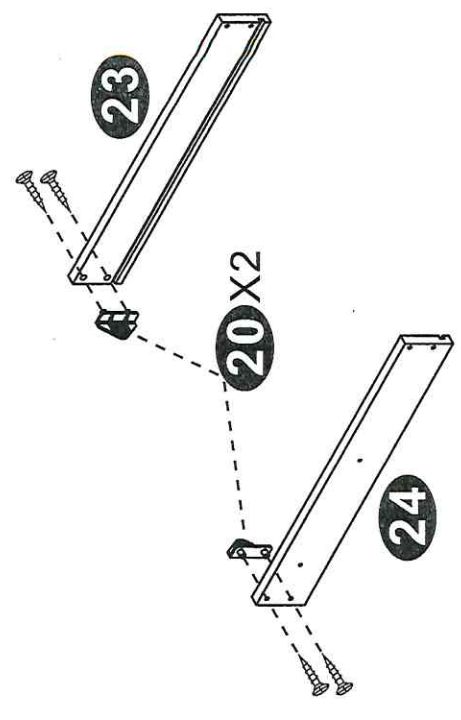
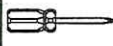

16

G 3X12 MM
x8



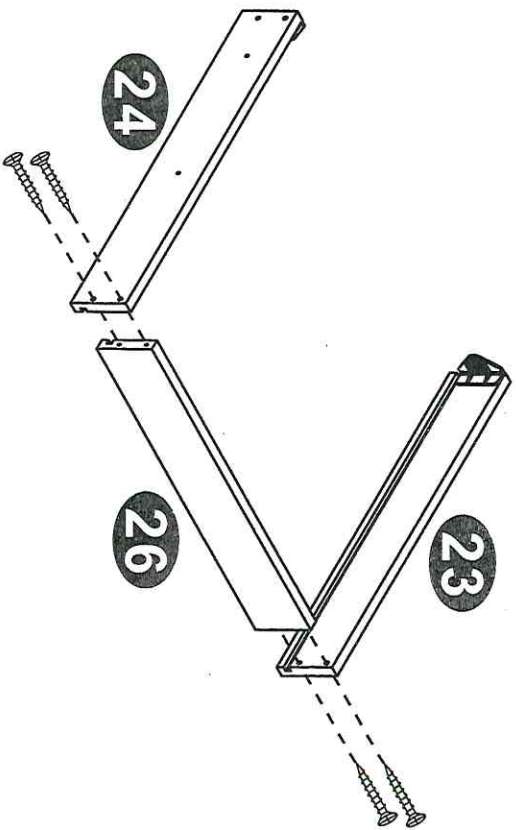
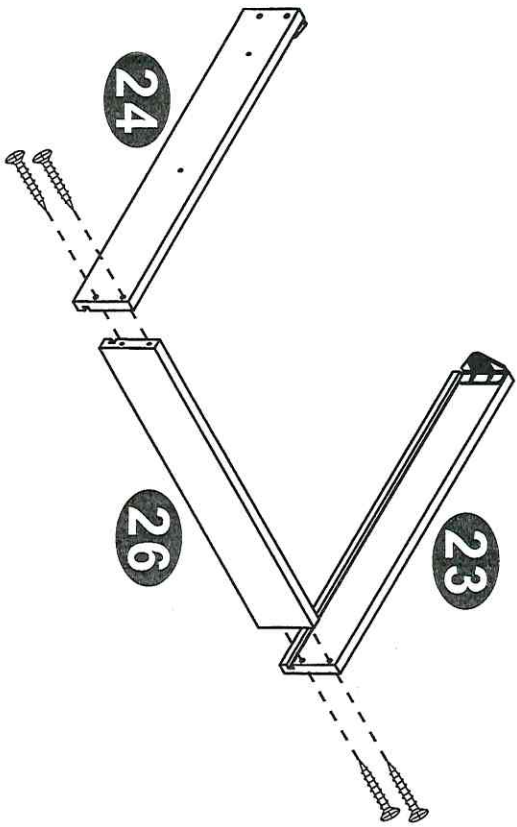

17

J 4X35 MM
x 8

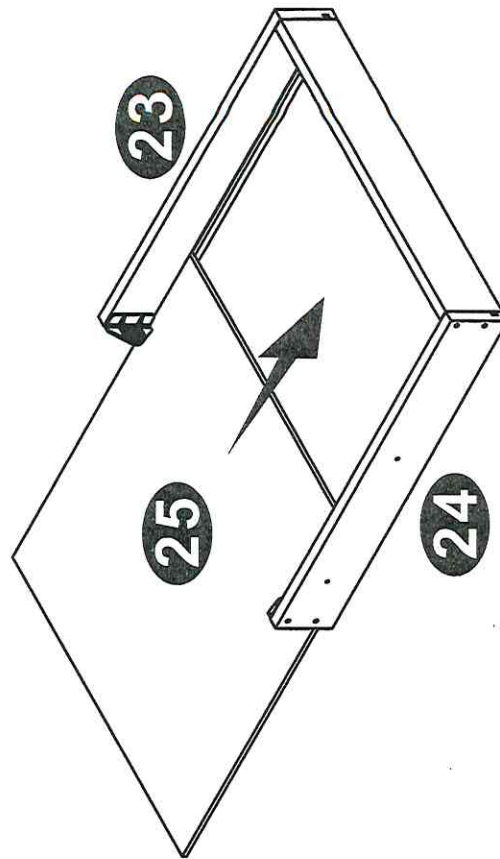
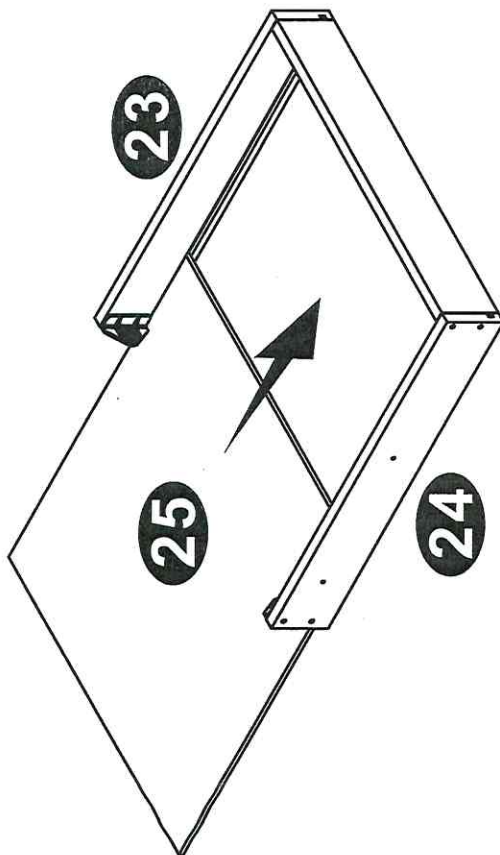



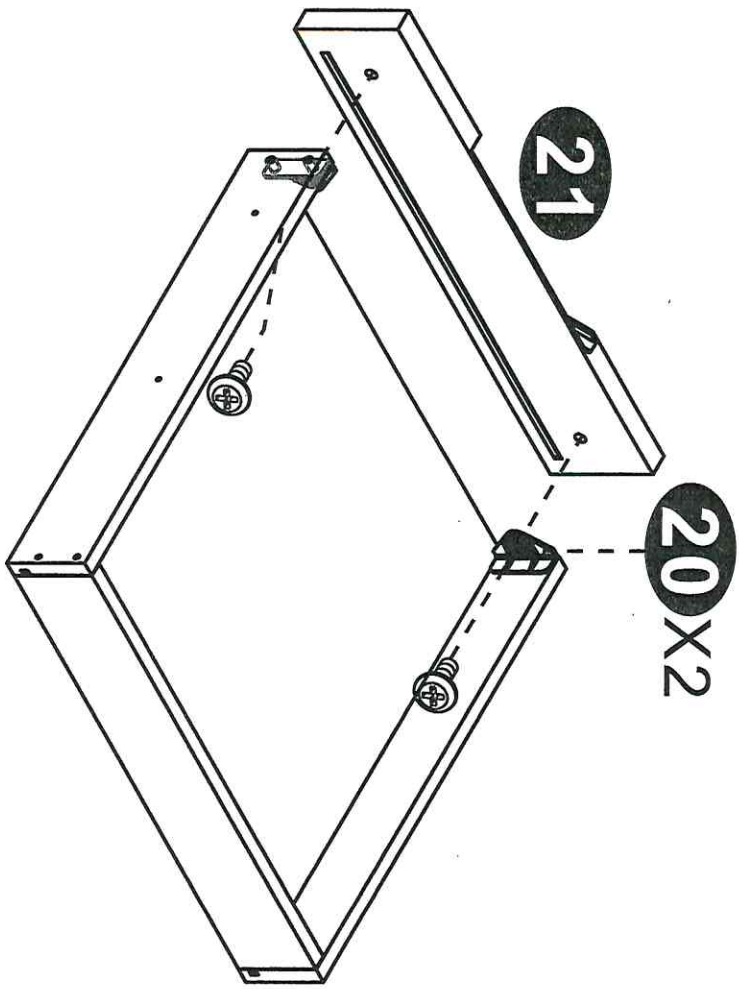

B 6X12 MM
x2

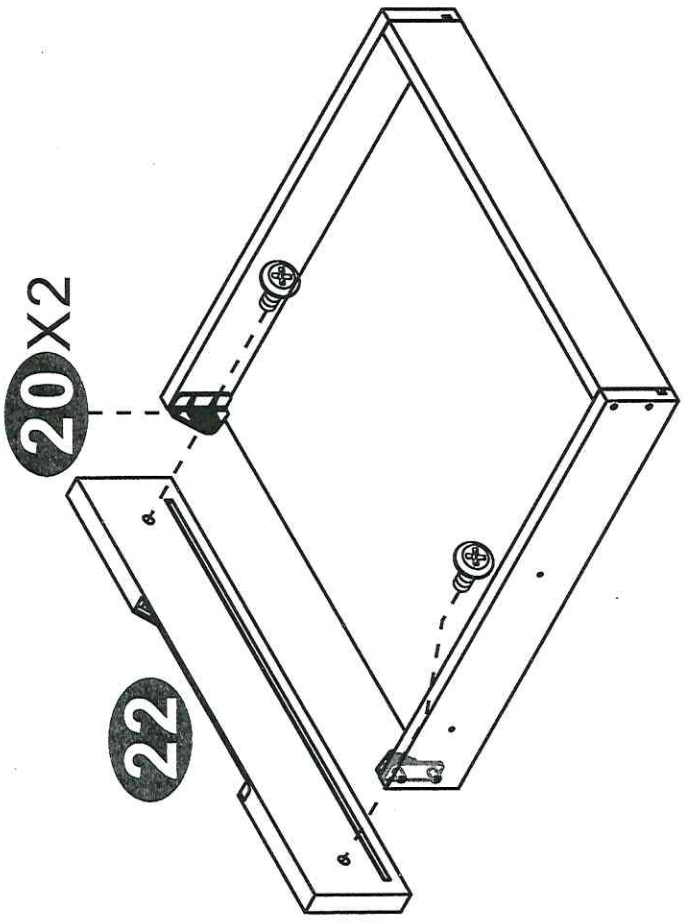

20

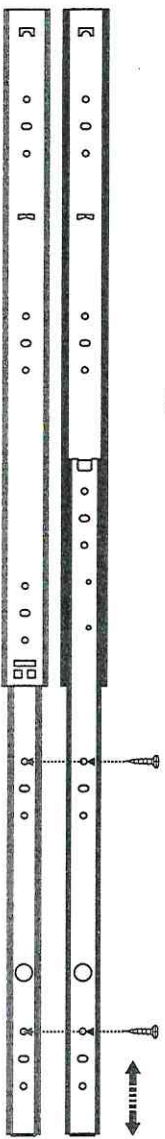
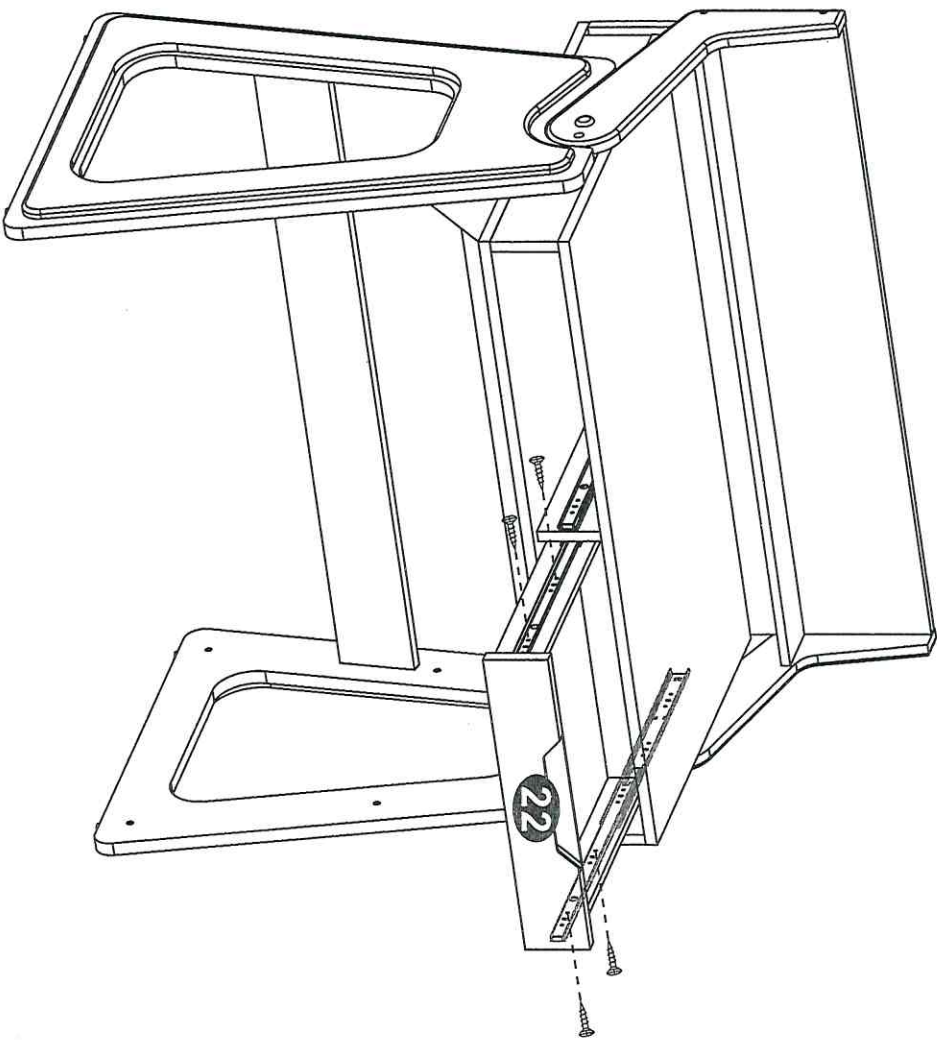

G 3X12 MM
x4



22

G 3X12 MM

x4

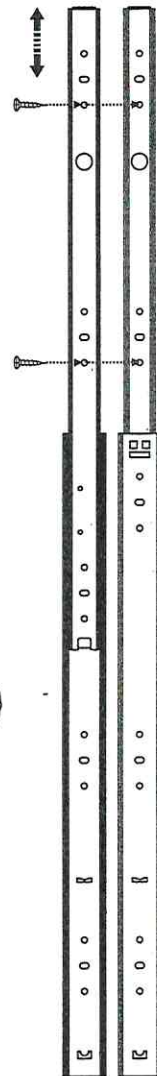
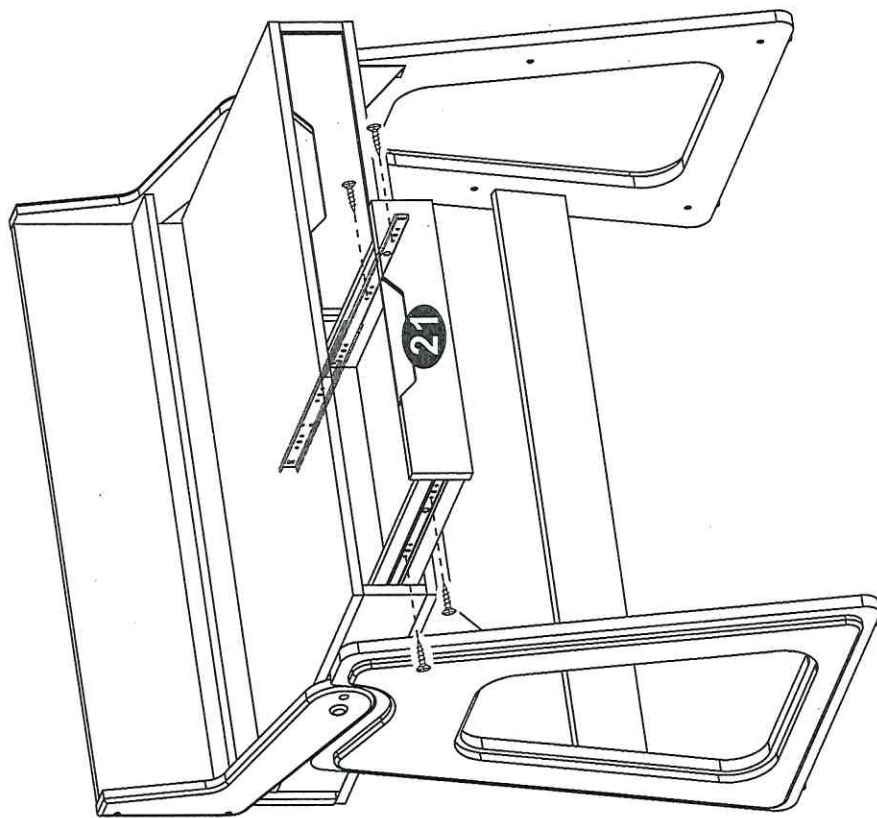

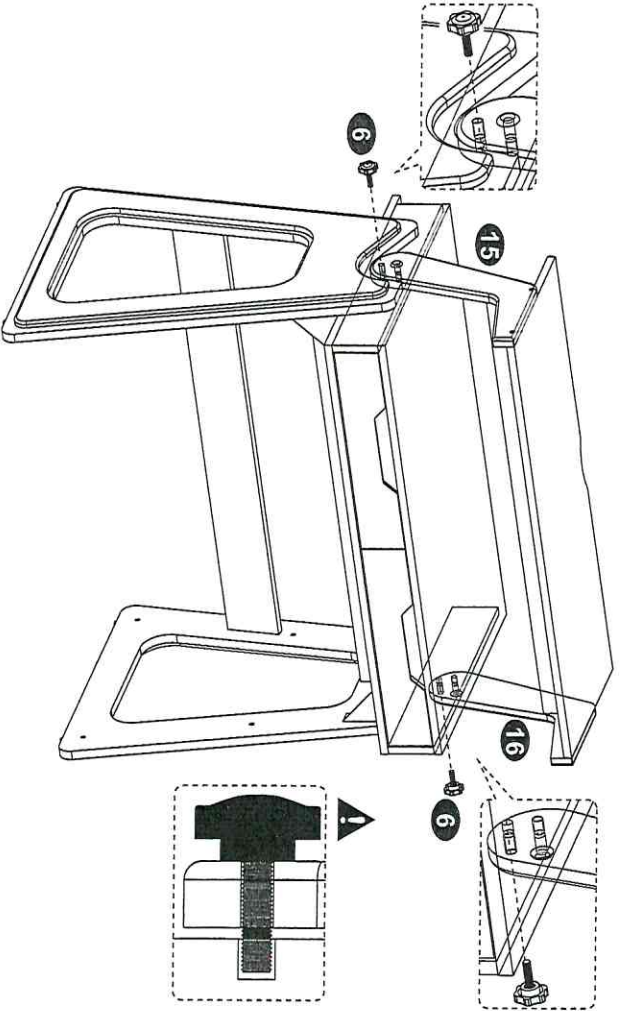

OR

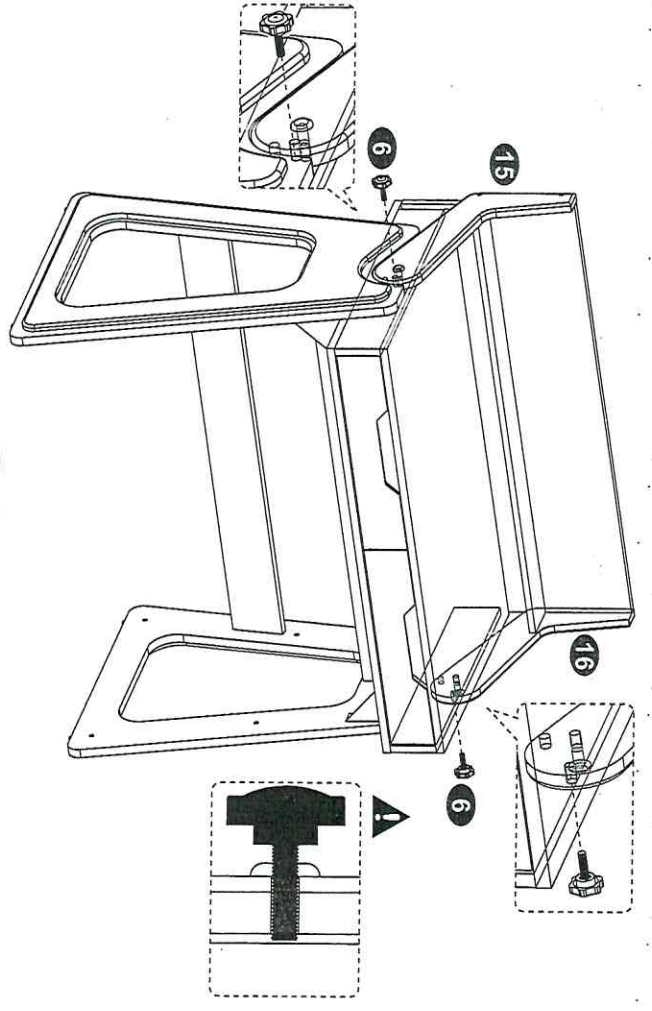

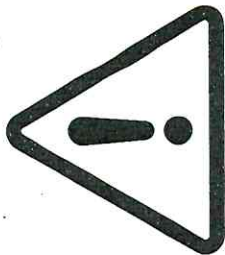
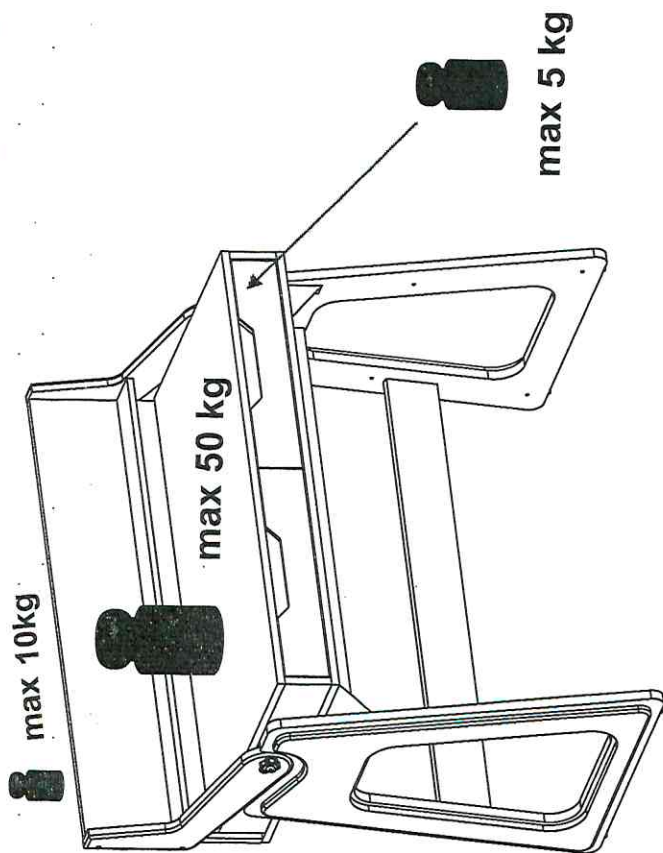

D	Überschreiten Sie die angegebenen Maximalbelastungen nicht. Andernfalls kann das Möbelstück beschädigt oder zerstört werden.
GB	Do not exceed the maximum loads specified. Otherwise, the furniture may sustain damage or be irreparably damaged.
FR	Ne dépassez pas les charges maximum indiquées. Sinon, le meuble peut être endommagé ou détruit.
IT	Non superare il carico massimo indicato. Altrimenti il mobile rischia di rovinarsi o frantumarsi.
NL	Overschrijd de aangegeven maximale belastingen niet. Anders kan het meubelstuk worden beschadigd of vernield.
PL	Nie wolno przekraczać podanych maksymalnych wartości obciążenia. W przeciwnym razie mebel może zostać uszkodzony lub zniszczony.
CZ	Nepřekračujte uvedená maximální zátěž. V opačném případě může dojít k poškození nebo zničení nábytku.
SK	Neprekročte uvedené maximálne zaťaženia. V opačnom prípade sa môže nábytok poškodiť alebo zničiť.
HU	Tartsa be az engedélyezett maximális terhelhetőség/teljesítményt. Különben a bútor és annak alkatrészei megsérülhetnek, tönk्रे mehetnek.
RO	Nu depășiți solicitările maxime specificate. Altfel puteți să deteriorați sau să distrugeți piesa de mobilier.
TR	Belirtilen azami yük değeri ni aşmayın, aksi takdirde mobilya parçasi zarar görebilir veya kullanilamaz hale gelebilir.
RU	Не допускается превышение указанных максимальных нагрузок. В противном случае возможно повреждение или разрушение мебели.

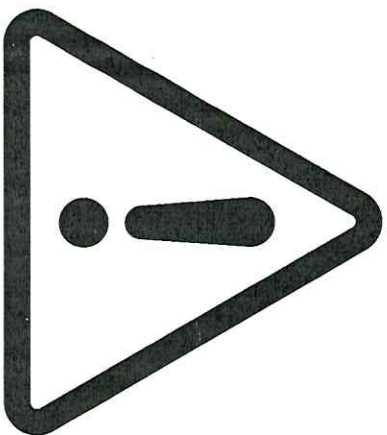

D	Ziehen Sie alle Schrauben sowie tragende Verbindungsstelle nach ca. 5 Wochen nach, um eine dauerhafte Standsicherheit zu gewährleisten.
GB	After approx. 5 weeks, tighten all screws and load-bearing connecting parts to ensure permanent stability.
FR	Resserrez toutes les vis ainsi que les pièces de fixation au bout d'environ 5 semaines pour garantir une sécurité de fixation durable.
IT	Ristringere tutte le viti e giunture dopo ca. 5 settimane, al fine di garantire una durevole solidità.
NL	Draai alle schroeven en ook dragende verbindingstukken na ca. 5 weken nog eens vast, zodat een continue stabiliteit wordt gegarandeerd.
PL	Prosimy po ok. 5 tygodniach dokręcić wszystkie wszystkie śruby w elementach łączeniowych. Zagwarantuje to Państwu trwałość i stabilność połączeń.
CZ	Dotáhněte všechny šrouby a nosné spojovací díly přibližně po 5 týdnech, aby se zaručila trvalá stabilita.
SK	Po cca 4 týždňoch dotiahnite skrutky, aby bola zaručená ich trvalá stabilita.
HU	Húzza utána – kb. 5 hét múlva – az összes csavart és a teherhordó összekötő-alkatrészeket a biztonság érdekében.
RO	Reținu a asigura o stabilitate de durată, strângeți dură cca. 5 săptămâni toate șuruburile, precum și toate elementele portante de legătură.
TR	Tüm vida ve taşıyıcı bağlantı parçalarını kalıcı bir durgun güvenliğini sağlamak için yaklaşık 5 hafta sonra tekrar sıkınız.
RU	Подкрутите все болты, а также несущие соединительные детали пригл. через 5 недель для обеспечения устойчивости в течение длительного времени.
D	Bitte nur mit einem Staubtuch oder leicht feuchtem Lappen reinigen. Keine scheuernden Putzmittel verwenden.
GB	Please only clean with a duster or a damp cloth. Do not use any abrasive cleaners.
FR	Veillez nettoyer uniquement avec un chiffon à poussière ou un chiffon légèrement humide. Ne pas utiliser de détergent abrasif.
IT	Si raccomanda di pulire solo con un panno per la polvere o uno strofinaccio umido. Non utilizzare detersivi abrasivi.
NL	Reinig alleen met een stofdoek of een lichtjes vochtige doek. Gebruik geen schurende poetsmiddelen.
PL	Czyszczenie należy wykonać wyłącznie za pomocą ściereczki lub lekko nawilżonego ręcznika. Nie stosować środków czyszczących do szorowania.
CZ	Čistěte prosím jen prachovkou nebo lehce navlhčeným hadrem. Nepoužívejte drhnutí čisticí prostředky.
SK	Na čistenie používajte len prachovku alebo zvlhka navlhčenú utierku. Nepoužívajte žiadne drhnuce čistiace prostriedky.
HU	Kérjük, csak portóris kendővel vagy enyhén nedves ronggyal tisztítsa. Ne használjon dörzsható tisztítószert.
RO	Vă rugăm să utilizați la curățare exclusiv o cârpă de șters praful sau o cârpă ușor umezită. Nu utilizați substanțe de curățat abrazive.
TR	Lüften sadece bir toz bezyle veya hafif nemli yumuşak bir bezle siliniz. Asındırıcı temizlik malzemesiyle kullanmayınız.
RU	Очищайте от пыли тряпкой или слегка влажной ветошью. Не допускаются применение чистящих средств, не предназначенных для ухода за мебелью.

